



**RACINE
RAILROAD
PRODUCTS**

Anchormatic

INNOVATIVE DESIGN FROM RACINE RAILROAD PRODUCTS

Boxing Feature For In-track Welding Operations

"Exclusive" with the Racine Anchormatic is Boxing Lock-out or Selective Boxing. This feature gives you the opportunity to lock-out either side of the boxing feature, leaving one anchor a minimum of 2" away from the tie. No more anchors to knock off and then re-apply. A great labor saver. Anchors are applied at the rate of 6-10 tie per minute.

Easy Set-up and Operation—Reliable Service

Using simple adjustments and program logic control technology machine operation is made simple. Proven reliable machine design, provides years of trouble free service.

Large Hopper Holds 800-1,000 Anchors

Hopper design allows for longer work cycle before need to reload. Hopper also pivots upward, bringing the anchors toward the operator, for ease of operation.

Simplify Anchor Loading Process

Hydraulic motor driven winch, located on the boom is operated by a retractable push button hand control, making anchor loading quick and safe.

Anchor Holders

Available for all modern day anchor types.

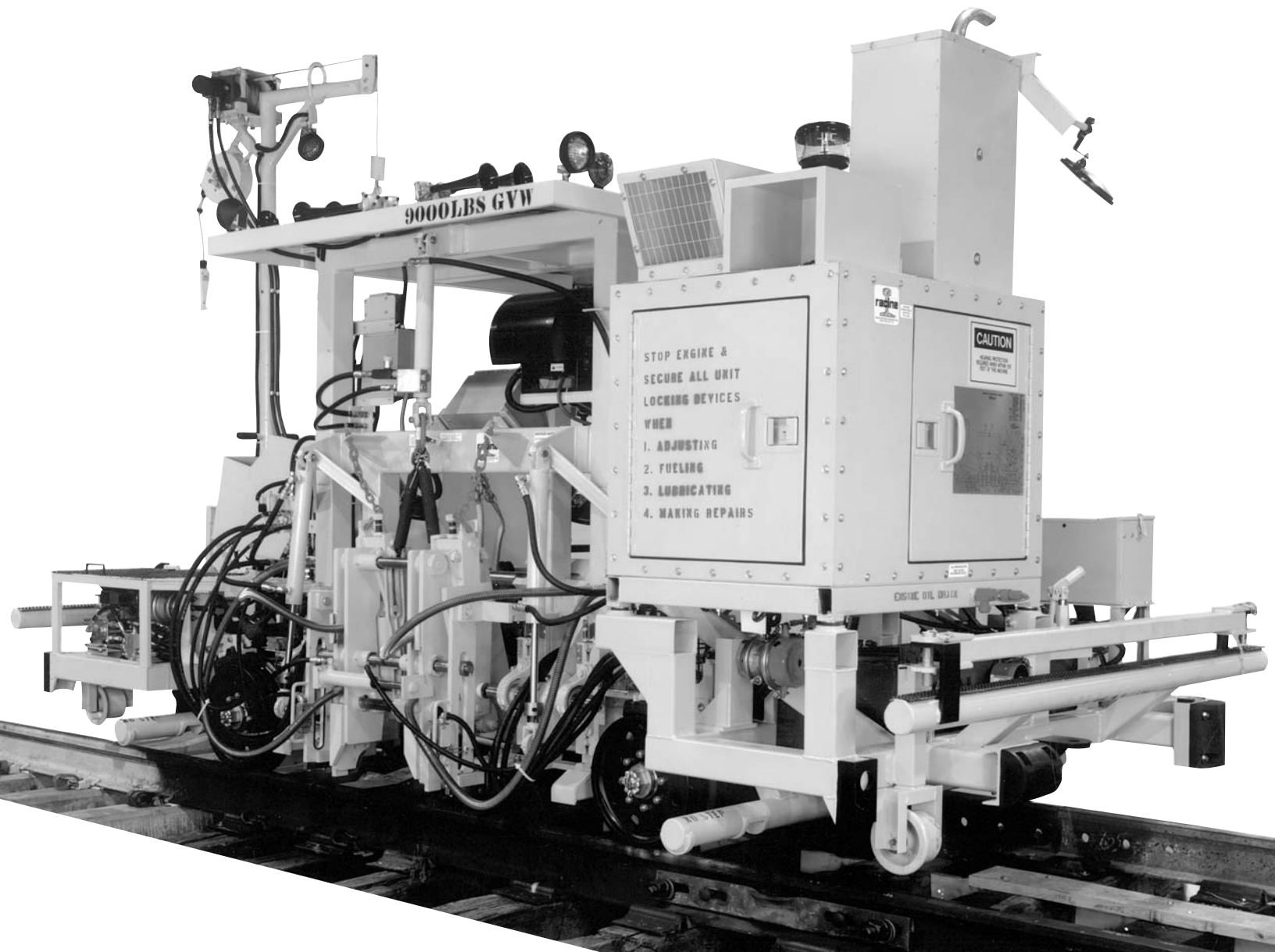

APPLY OPERATION

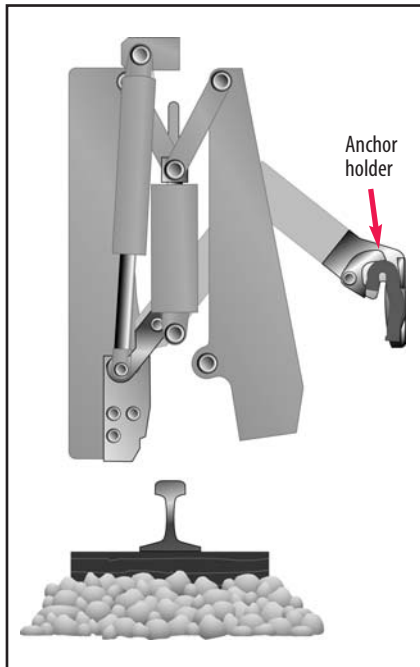

Anchor is automatically loaded into holder on setter arm through exclusive chute feed mechanism.

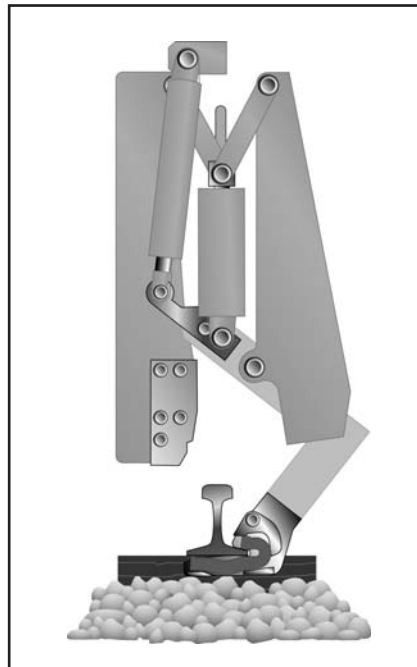

Setter arm swings down and precisely positions anchor on rail.

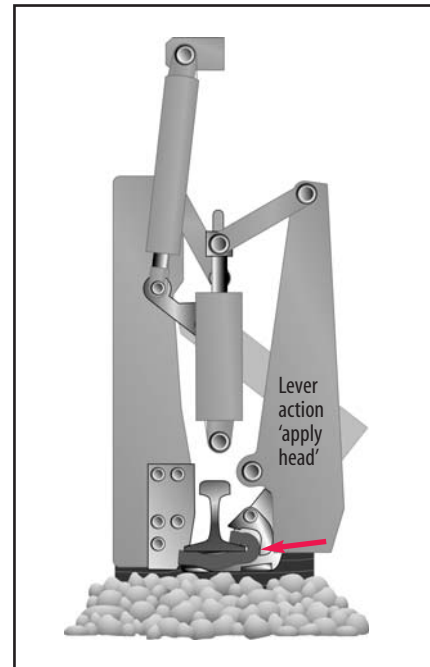

Lever action 'apply head' pushes anchor onto rail with consistent pressure eliminating the need for stressing hammer blows. Anchors can be applied at the rate of 6-10 ties per minute—boxed or unboxed.

PRODUCT SPECIFICATIONS:

- Powered by Hatz, air cooled, diesel engine.
- Structural steel frame with derail skids, key hole tie downs, rubber bumpers.
- Insulated axles with self aligning, double row spherical roller bearings and axle locks.
- Propulsion is 4 wheel chain driven using axle mounted split sprockets with a travel speed of 35 MPH.
- 12 VDC negative ground with a 60 amp system fuse, using a SAE #4D battery. Circuit breakers for lights and accessories.
- 30 gallon hydraulic reservoir with clean out covers, guarded fluid level & temperature gauge.
- 36 gallon fuel tank with 2" diameter fill neck, bottom sump and mechanical fluid level gauge.
- Dimensions: L-177" W-95" H-116.5" including boom Weight: 10,000 lb GVW (dry)

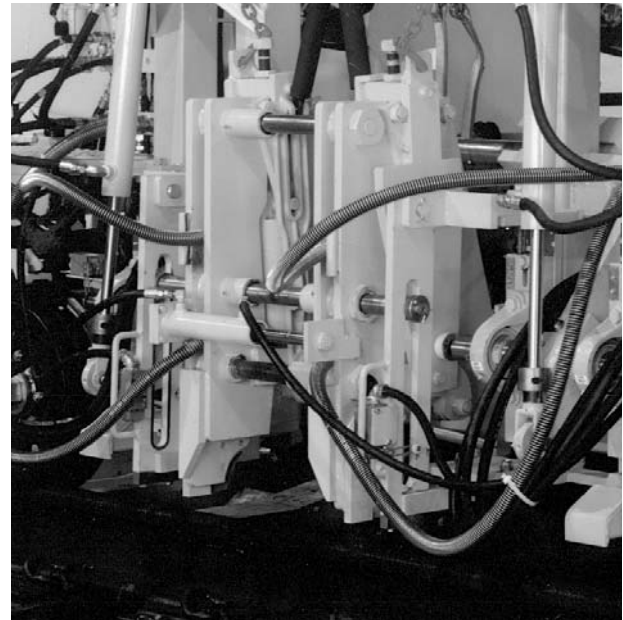

Visit our web site: www.racinerailroad.com

For a complete list of specifications and machine options available, contact
Racine Railroad Products at: Tel (262) 637-9681 • Fax (262) 637-9069 • email: custserv@racinerailroad.com
1524 Frederick Street • Racine, Wisconsin 53404