



**RACINE  
RAILROAD  
PRODUCTS**

# Dual Anchor Adjuster/Cribber

INNOVATIVE DESIGN FROM RACINE RAILROAD PRODUCTS

**The Racine Dual Anchor Adjuster/Cribber is designed to squeeze anchors in full crib on one or both rails simultaneously. Can also be outfitted to straighten skewed concrete ties (with optional tools).**

## Applications

- Out of Face anchor adjusting & anchor replacement projects
- Tie gang anchor squeezing after tie replacement
- Rail relay & tie pad changing projects on concrete ties

## Efficient

No need for multiple machines. This self propelled, single operator machine uses cribbing tools to remove ballast from beneath each anchor to allow for anchor adjusting. With optional tooling, the machine can crib ballast and straighten skewed concrete ties.

## Great Labor Saver

Only need one operator to do both cribbing and adjusting. Reduces man-hours safely.

## Multiple Uses

Can be used as an independent anchor adjuster, cribber or tie straightener. Lessens the need for multiple machines in your equipment fleet.

## Production

Adjusts up to 12 ties per minute in "Adjust Only" mode and up to 8 ties per minute in "Cribbing/Adjust" mode. Track travel up to 25 MPH.

## PRODUCT SPECIFICATIONS:

- Engine: John Deere 4045D Diesel
- Fuel capacity: 30 gal
- Hydraulic capacity: 35 gal
- Dimensions: 189"L x 102"W x 91"H, 14,000 lbs

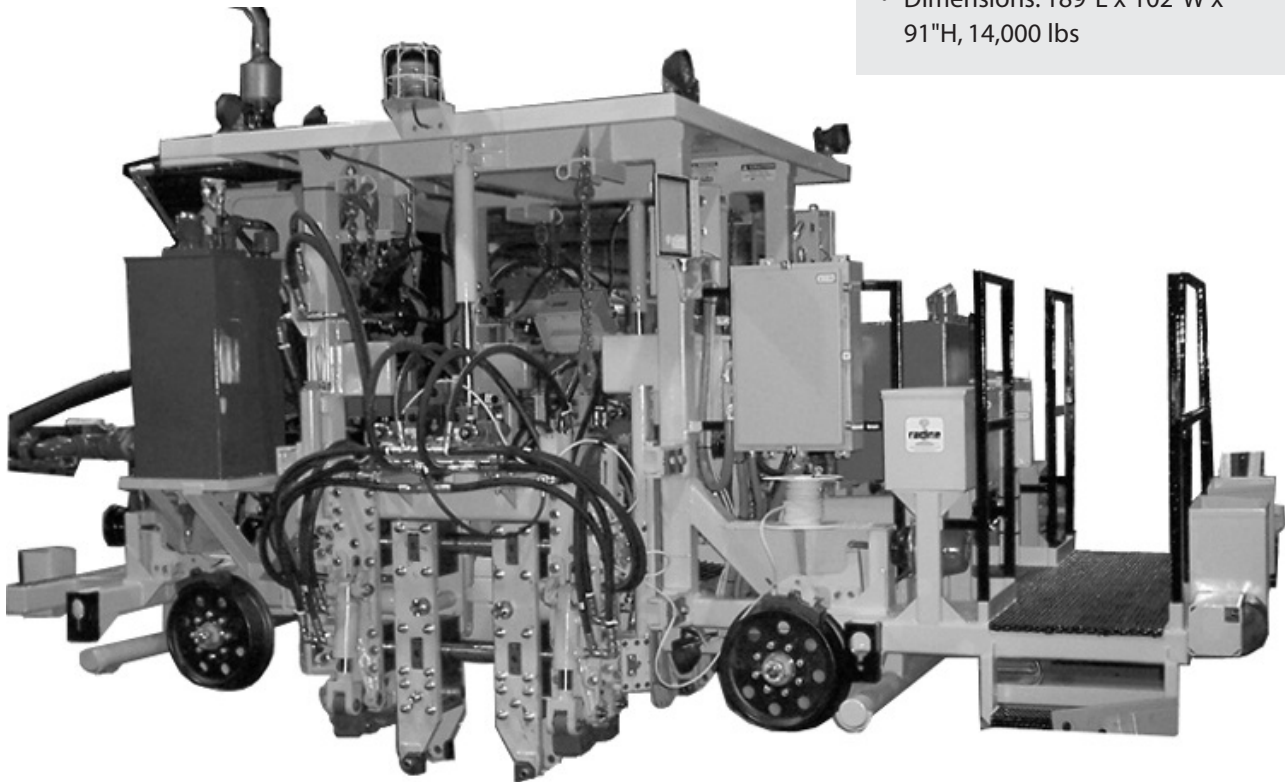

**Visit our web site: [www.racinerailroad.com](http://www.racinerailroad.com)**

For a complete list of specifications and machine options available, contact  
Racine Railroad Products at: Tel (262) 637-9681 • Fax (262) 637-9069 • email: [custserv@racinerailroad.com](mailto:custserv@racinerailroad.com)  
1524 Frederick Street • Racine, Wisconsin 53404