



**RACINE  
RAILROAD  
PRODUCTS**

# Model-A Rail Drill Gas

INNOVATIVE DESIGN FROM RACINE RAILROAD PRODUCTS

## Durable, Reliable, Economical

Powered by a durable 3.5 HP Briggs & Stratton 4-cycle engine, the Racine Model-A Rail Drill has been a staple in the industry for over 35 years, with thousands of units working consistently in the field.

## Drill Through Joint Bars

One of the few rail drills on the market that has enough shaft length to drill through joint bars.

## Versatile

The Racine Model-A Rail Drill has a variable height adjustment, which allows for drilling 60 – 155 lb rail (including crane rail) with optional attachments without the need for custom rail blocks.

## Automatic Feed

Accurately controls feed rate and handles various sizes of drill bits. Feed rate is controlled by spring pressure. This extends bit life by eliminating heat build up that causes work hardening. Spindle speed is set at 110 RPM and can drill a 15/8" hole in 1 1/2 to 2 minutes.

### Model 910179

3.5 HP Briggs & Stratton 4-Cycle engine with 6:1 gear reduction

Capable of drilling 3/4" to 1 1/2" hole diameters

Weight: 139 lbs

Comes with chuck for 1" to 1 1/2" flat track bits or cobalt straight shank twist drill bits.

Available Option: Protective roll bar.

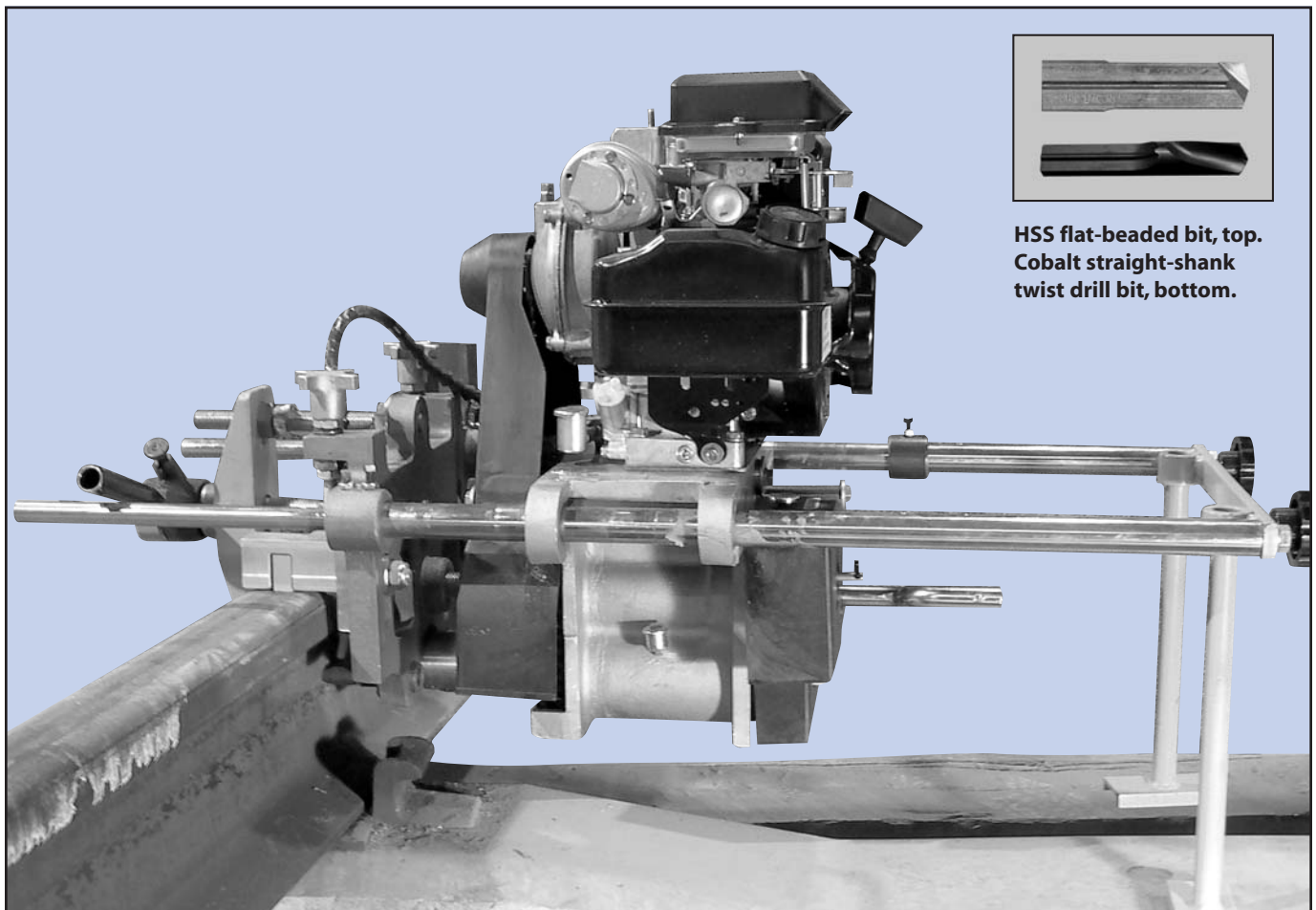

HSS flat-beaded bit, top.  
Cobalt straight-shank  
twist drill bit, bottom.

The Racine Model -A Drill is designed for drilling most rail sections worldwide.

Visit our web site: [www.racinerailroad.com](http://www.racinerailroad.com)

For a complete list of specifications and machine options available, contact  
Racine Railroad Products at: Tel (262) 637-9681 • Fax (262) 637-9069 • email: [custserv@racinerailroad.com](mailto:custserv@racinerailroad.com)  
1524 Frederick Street • Racine, Wisconsin 53404