



RRP
HYDRAULICS

Rail Weld-Shear

BUILT-TO-LAST HYDRAULIC TOOLS FROM RACINE RAILROAD PRODUCTS

Easy operation

The Hydraulic Rail Weld-Shear utilizes a controlled shear speed with a rapid retract feature to properly shear rail welds utilizing a single lever control for ease of operation.

Versatility

The unit is secured on the rail at four points with roller hold-downs for proper alignment and can operate at either 5 GPM or 10 GPM @ 2000 PSI.

Lightweight

One of the lightest in the market place, it can easily be maneuvered to fit inside the RRP Rail Puller.

Model 910091		
Hydraulic System	Open Center	
Frame Type	Tube	
Length	29 in. 73.66 cm	
Width	19 in. 48.26 cm	
Height	9.75 in. 24.77 cm	
Weight (Dry)	94 lbs. 42.7 kg	
Motor	N/A	
Hydraulic Rated Flow	GPM @ PSI	
	A-Port	5/10 2000
		LTR @ BAR
		20/40 140
Hydraulic Relief Pressure	N/A	

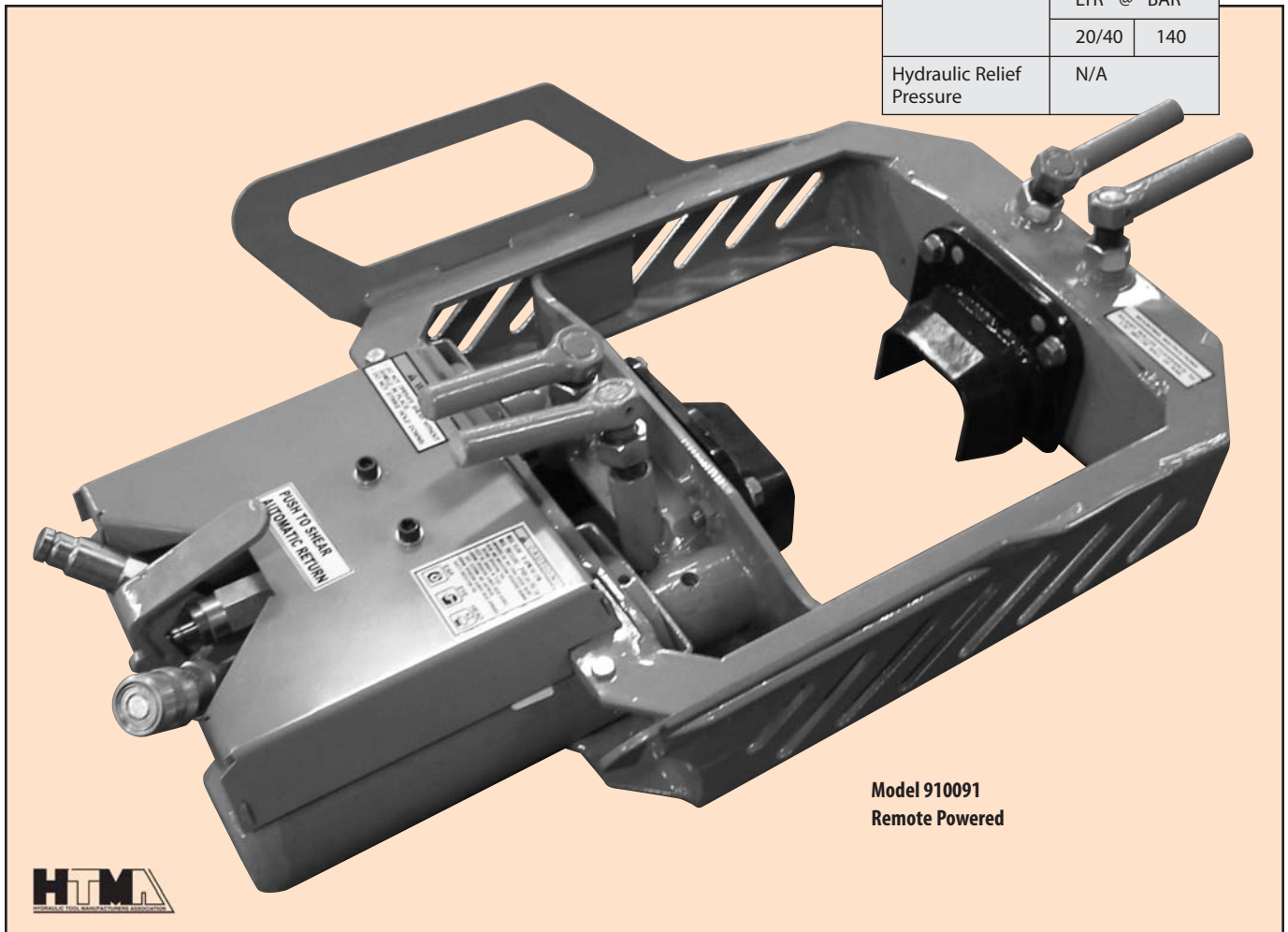

Model 910091
Remote Powered



Visit our web site: www.racinerailroad.com

For a complete list of specifications and machine options available, contact
 Racine Railroad Products at: Tel (262) 637-9681 • Fax (262) 637-9069 • email: custserv@racinerailroad.com
 1524 Frederick Street • Racine, Wisconsin 53404