

NO.	QTY	DESCRIPTION	PART NO.
1	4	ADAPTER, .12 NPT(M) X .38 TBG BRASS	463692
2	2	BRACKET, CHUTE AIR CYLINDER	780307
3	2	BRACKET, CHUTE CYLINDER	780305
4	2	BRACKET, PIVOT	470569
5	2	CLAMP, HOSE: 1.12 DIA	461940
6	2	CLEVIS, .62-18 THD .5 PIN	465828
7	2	CYLINDER, AIR: 3 X 15	470568
8	2	ELBOW, 90°: .38 NPT(M) X .38 NPT(F)	461587
9	2	GUARD, CHAIN	471758
10	2	GUARD, CHAIN	471759
11	1	INSTRUCTIONS, CONVEYOR CHUTE CYLINDER	800243
12	2	LOCK, CONVEYOR CHUTE	780725
13	8	NUT, HEX ES: .25-20	491232
14	8	NUT, HEX FLG: .38-16	491332
15	2	PIN, CLEVIS: .5 X 1.5	453620
16	2	PIN, CLEVIS: .5 X 1.75	462772
17	4	PIN, COTTER: .16 X .75	491345
18	4	REDUCER, .38 NPT(M) X .12 NPT(F)	404498
19	8	SCR, HEX: .25-20 X 1.25	400687
20	8	SCR, HEX: .38-16 X 1	400717
21	602	TBG, .38 OD X .06 W NYLON	006740
22	4	VALVE, FLOW CONTROL	465830
23	16	WASHER, FLT: .25	401626
24	8	WASHER, FLT: .31	401620
25	2	WASHER, FLT: .5	491405
26	2	WASHER, FLT: .5	491472

REQUIRED DRAWINGS:
714153 CONVEYORS
778362 PEDESTAL, CONVEYORS

DWG NO
792928

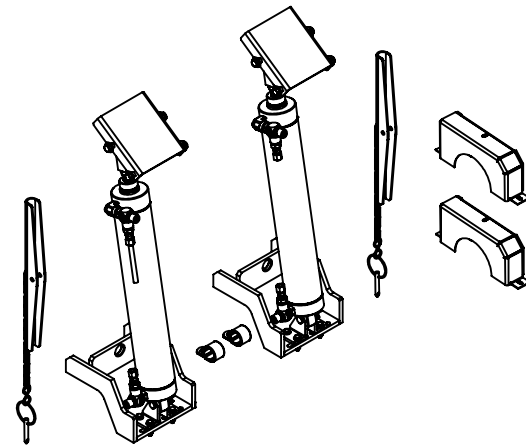

REV	EN	DESCRIPTION	DATE	DRN
A	---	PROTOTYPE	6-16	MSO
DIMENSION TOLERANCES UNLESS OTHERWISE SPECIFIED				
LINEAR	.XX=±.03	.XXX=±.010		
ANGULAR	X°=±1°	X.X°=±.5°		
SURFACE FINISH 125/		SMOOTH ALL SHARP EDGES		
NOT TO EXCEED		CLEAN ALL WELDS		
THIS PRINT AND ALL INFORMATION WITHIN BELONGS TO RACINE RAILROAD PRODUCTS				
RACINE RAILROAD PRODUCTS				
RACINE, WISCONSIN USA				
DESCRIPTION				
KIT, CONVEYOR CHUTE CYLINDER				
MATERIAL				
SEE BOM				
USED ON			SCALE	DATE
			1:16	06-08-16
DRN	CHK	APP	JOB NO	SHEET
MSO			RD040192	1 OF 1
EXP NO			DWG NO	
			792928	