

NO.	QTY	DESCRIPTION	PART NO.
1	2	PLACARD, .75 FASTENER TORQUE	473293
2	2	PLACARD, .38 FASTENER TORQUE	473295
3	16	SCR, DRIVE: #4 X .25	491673
4	1	INSTRUCTIONS, FASTENER TORQUE PLACARDS (DAS)	800275

DWG NO

793015

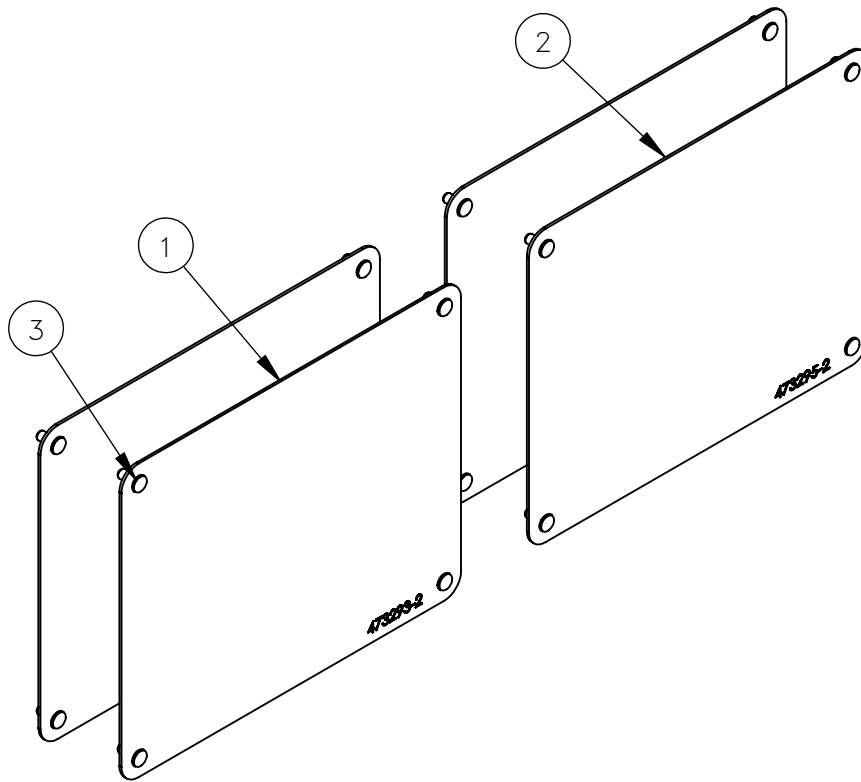

NOTE:
FOR USE WITH COMBO DAS MACHINES
913569, 914569, 931569, 933569

REV	EN	DESCRIPTION	DATE	DRN
1	3082	NEW RELEASE	4-18	MSO
2	3635	ADDED NOTE	10-18	MSO

DIMENSION TOLERANCES UNLESS OTHERWISE SPECIFIED

LINEAR	.XX=±.03	.XXX=±.010
ANGULAR	X°=±1°	X.X°=±.5°

SURFACE FINISH 125/ ✓ SMOOTH ALL SHARP EDGES
NOT TO EXCEED ✓ CLEAN ALL WELDS

THIS PRINT AND ALL INFORMATION WITHIN
BELONGS TO RACINE RAILROAD PRODUCTS

RACINE RAILROAD PRODUCTS

RACINE, WISCONSIN USA

DESCRIPTION

KIT, DAS FASTENER TORQUE PLACARDS

MATERIAL

SEE BOM

USED ON

SCALE

DATE

1:2

04-19-18

DRN

CHK

APP

JOB NO

SHEET

MSO

RD140001

1 OF 1

EXP NO

DWG NO

793015