

DWG NO  
793072

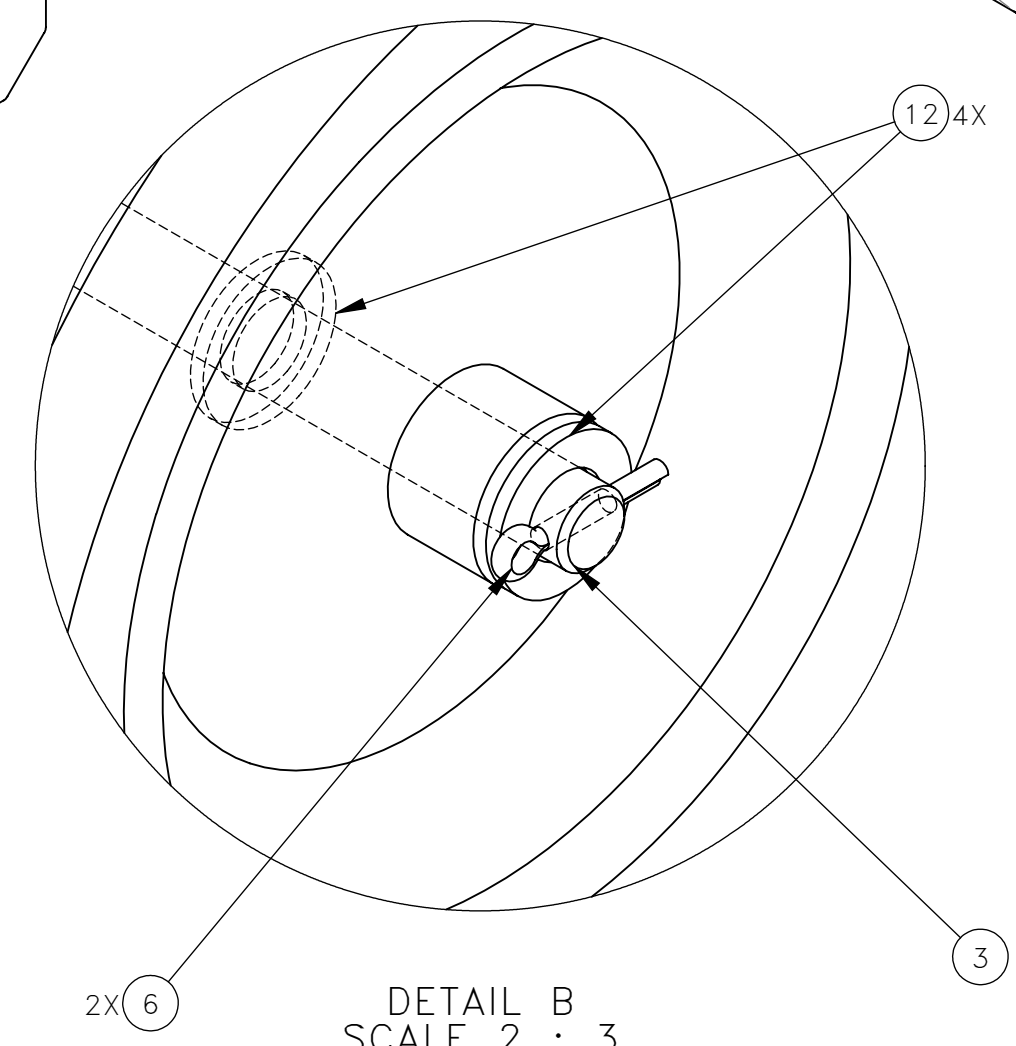

DETAIL B  
SCALE 2 : 3

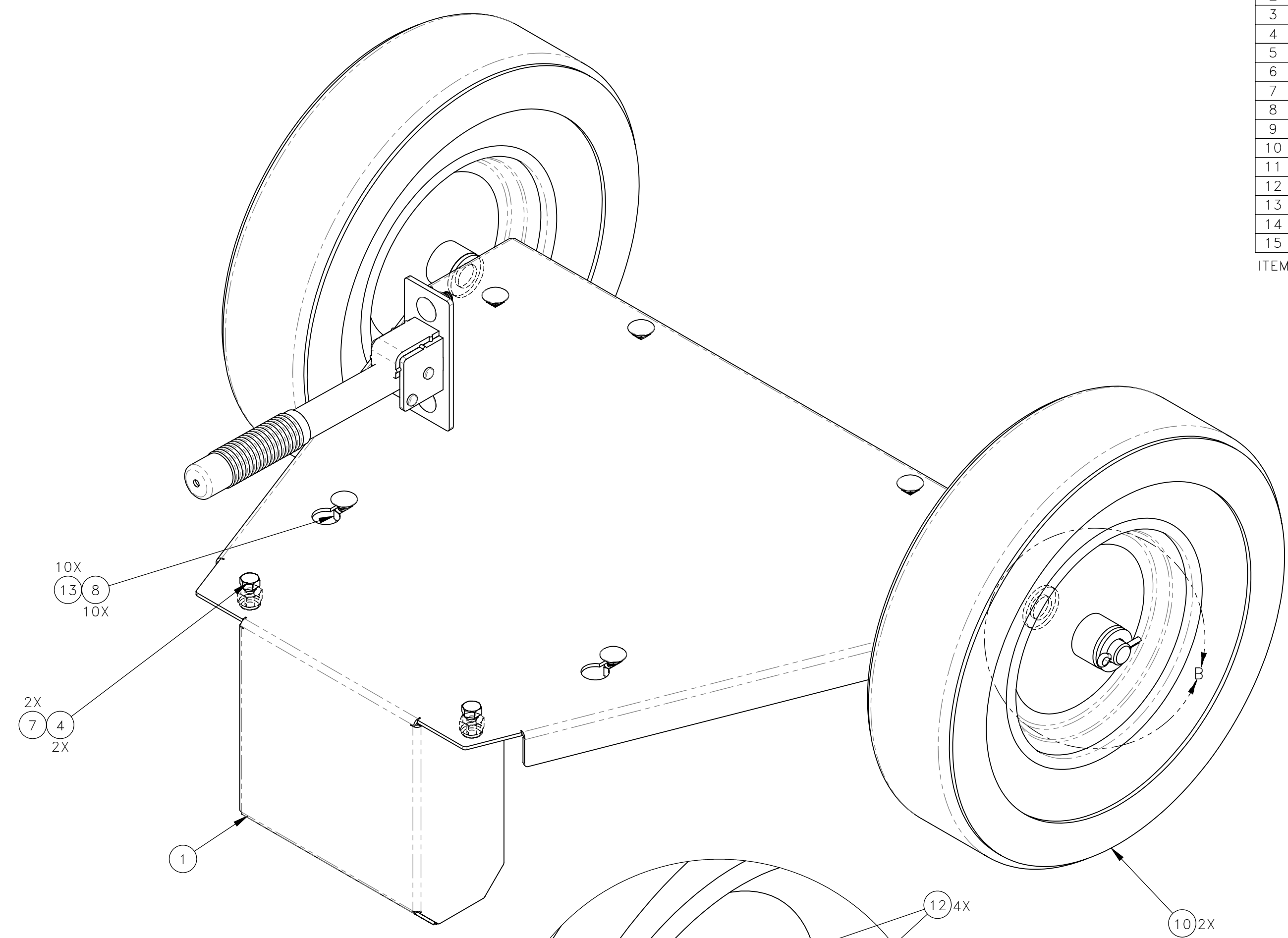
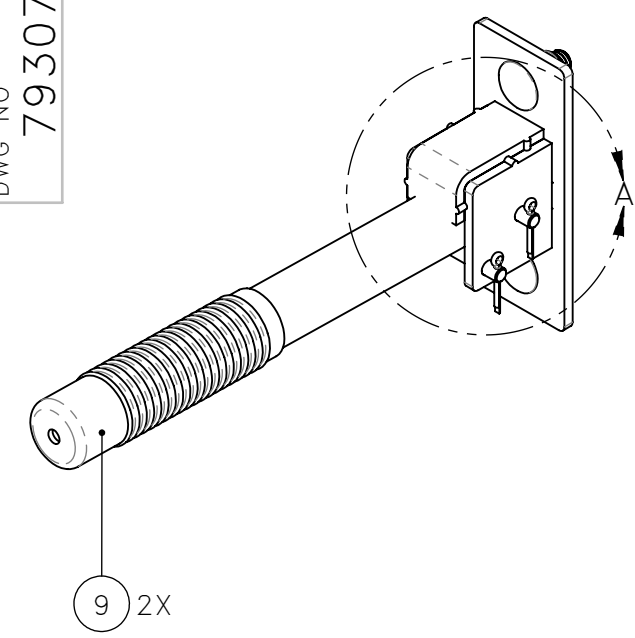
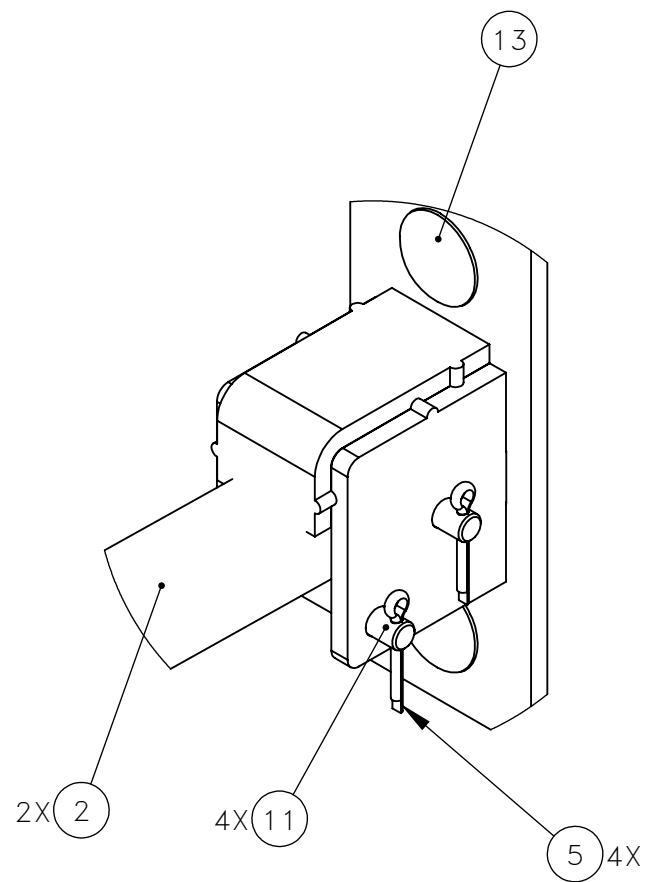

DETAIL A  
SCALE 2 : 3

NO.	QTY	DESCRIPTION	PART NO.
1	1	BASE, WHEEL KIT	320967
2	2	HANDLE	320976
3	1	AXLE	320990
4	2	SCR, HEX: .38-16 X 1	400717
5	4	PIN, COTTER: .09 X .75	400897
6	2	PIN, COTTER: .19 X 1.25	400903
7	2	NUT, HEX ES: .38-16 HVY	404401
8	10	NUT, HEX ES: .38-16	450577
9	2	GRIP, HANDLE	458472
10	2	WHEEL, RUBBER 8"	474936
11	4	PIN, CLEVIS: .25 X 1.75	491297
12	4	WASHER, FLT: .75	491344
13	10	SCR, CARR: .38-16 X 1	492159
14	2	BASE, HANDLE	781885
15	1	INSTRUCTIONS, HPU WHEEL KIT	800329

ITEM 15 NOT SHOWN

REV	EN	DESCRIPTION	DATE	DRN
1	4815	NEW RELEASE	1-20	DCM

DIMENSION TOLERANCES UNLESS OTHERWISE SPECIFIED			
LINEAR	.XX=±.03	.XXX=±.010	
ANGULAR	X°=±1°	X.X°=±.5°	
SURFACE FINISH NOT TO EXCEED	125 ✓	SMOOTH ALL SHARP EDGES CLEAN ALL WELDS	

THIS PRINT AND ALL INFORMATION WITHIN  
BELONGS TO RACINE RAILROAD PRODUCTS

**RACINE RAILROAD PRODUCTS**  
RACINE, WISCONSIN USA

DESCRIPTION	KIT, HPU WHEEL		
-------------	----------------	--	--

MATERIAL	SEE BOM		
----------	---------	--	--

USED ON	719488	SCALE	DATE
		1:12	XX-XX-XX

DRN	CHK	APP	JOB NO	SHEET
XXX			RD190003	1 OF 1

DWG SIZE	CATALOG	DWG NO
C	A	793072