

DETAIL B
TYPICAL EACH END
SCALE 1 : 1

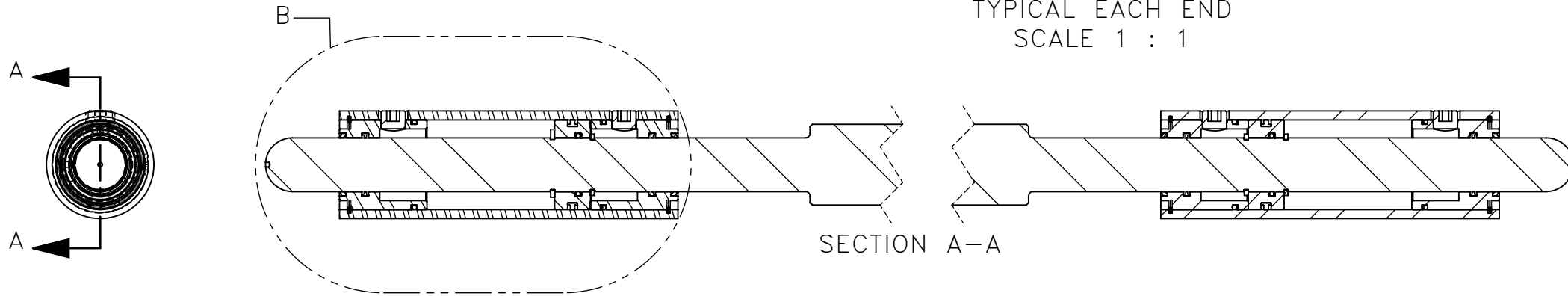

SECTION A-A

455137 SEAL KIT
AURELIUS #21238
ALL DIMENSIONS ARE FOR REFERENCE ONLY

FOR SERVICE ONLY

NO.	QTY.	DESCRIPTION	PART NO.
1	4	RING, RETAINING FOR 2.63 ID TUBE	475045
2	4	RING, SNAP	475046
3	2	O-RING	475047
4	4	O-RING	475048
5	4	WIPER, ROD	475049
6	2	SEAL, PISTON	475050
7	4	SEAL, U CUP	475051
8	4	RING, BACKUP	475054
9	4	RING, BACKUP	475055

REV	EN	DESCRIPTION	DATE	DRN
1	4781	NEW RELEASE	2-20	PR
DIMENSION TOLERANCES UNLESS OTHERWISE SPECIFIED				
LINEAR		.XX=±.03	.XXX=±.010	
ANGULAR		X°=±1°	X.X°=±.5°	
SURFACE FINISH		125/	SMOOTH ALL SHARP EDGES CLEAN ALL WELDS	
NOT TO EXCEED				
THIS PRINT AND ALL INFORMATION WITHIN BELONGS TO RACINE RAILROAD PRODUCTS				
RACINE RAILROAD PRODUCTS RACINE, WISCONSIN USA				
DESCRIPTION				
KIT, 455137 SEAL				
MATERIAL				
PURCHASE				
USED ON		455137	SCALE	DATE
			1:4	02-11-20
DRN	CHK	APP	JOB NO	SHEET
PR			RD150002	1 OF 1
DWG SIZE		CATALOG	DWG NO	
B		S	793074	