

NO.	QTY	DESCRIPTION	PART NO.
1	1	PIN, CLEVIS: 1 X 6.5	316004
2	1	SWEEP, RAIL	320462
3	1	FLAT	320464
4	1	WASHER, FLT: 1	380025
5	2	SCR, HEX: .38-16 X 1.75	400718
6	1	PIN, COTTER: .19 X 1.5	400904
7	2	WASHER, FLT: .38	401621
8	1	FITTING, LUBE: .12 NPT(M)	401987
9	2	BRG, CAM FOLLOWER: 3 DIA	462749
10	2	NUT, HEX LOCK: .38-16	491488
11	1	BRACKET, ROLLER LEFT	782119
12	1	INSTRUCTIONS, ROLLERS LEFT MECHANISM KIT	800352

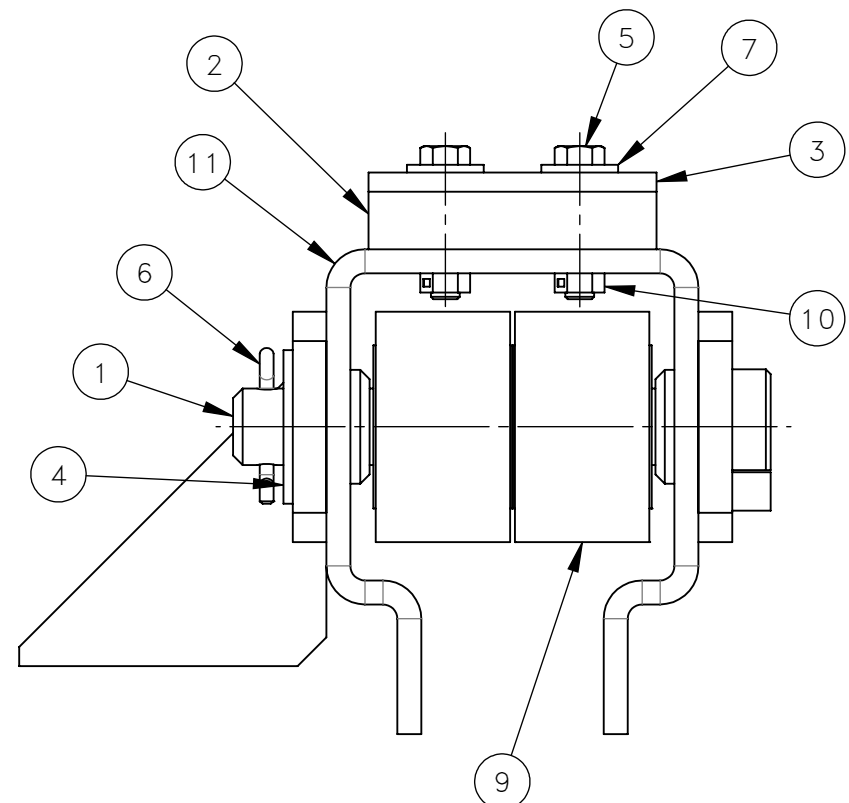
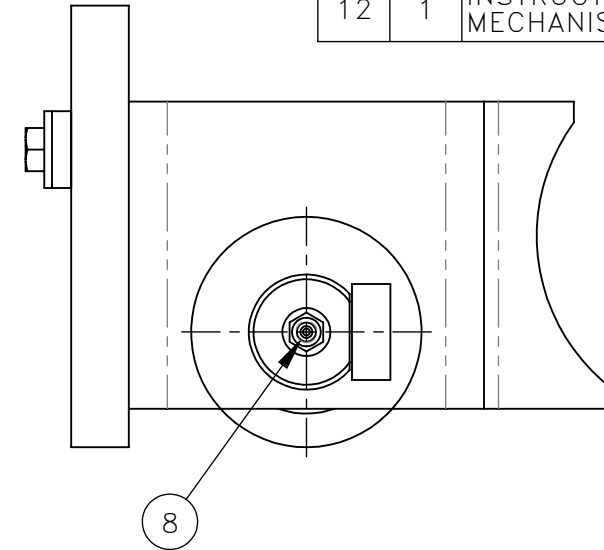
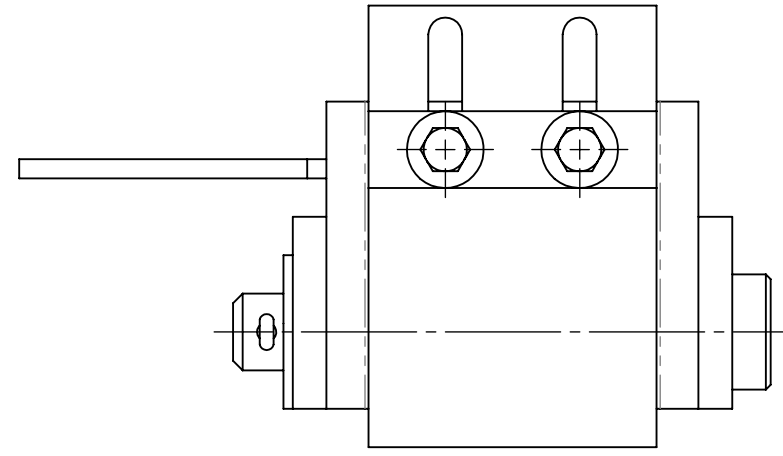
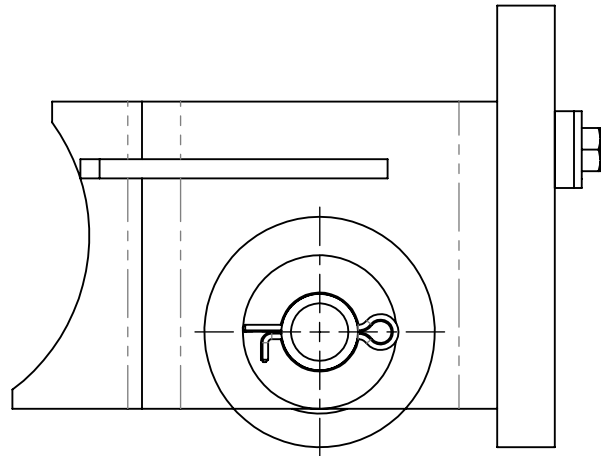

REV	EN	DESCRIPTION	DATE	DRN
1	5640	NEW RELEASE	4-21	ASM
DIMENSION TOLERANCES UNLESS OTHERWISE SPECIFIED				
LINEAR	.XX=±.03	.XXX=±.010		
ANGULAR	X°=±1°	X.X°=±.5°		
SURFACE FINISH		125 ✓	SMOOTH ALL SHARP EDGES CLEAN ALL WELDS	
NOT TO EXCEED				
THIS PRINT AND ALL INFORMATION WITHIN BELONGS TO RACINE RAILROAD PRODUCTS				
RACINE RAILROAD PRODUCTS RACINE, WISCONSIN USA				
DESCRIPTION				
KIT, ROLLERS LEFT				
MATERIAL				
SEE BOM				
USED ON		780838	SCALE	DATE
			1:2.5	04-13-21
DRN	CHK	APP	JOB NO	SHEET
ASM			RD150003	1 OF 1
DWG SIZE		CATALOG	DWG NO	
B		K	793111	