

NO.	QTY	DESCRIPTION	PART NO.
1	4	PIN, COTTER: .19 X 1.5	400904
2	4	ROLLER	719470
3	1	INSTRUCTIONS, GUIDE ROLLER KIT	800360

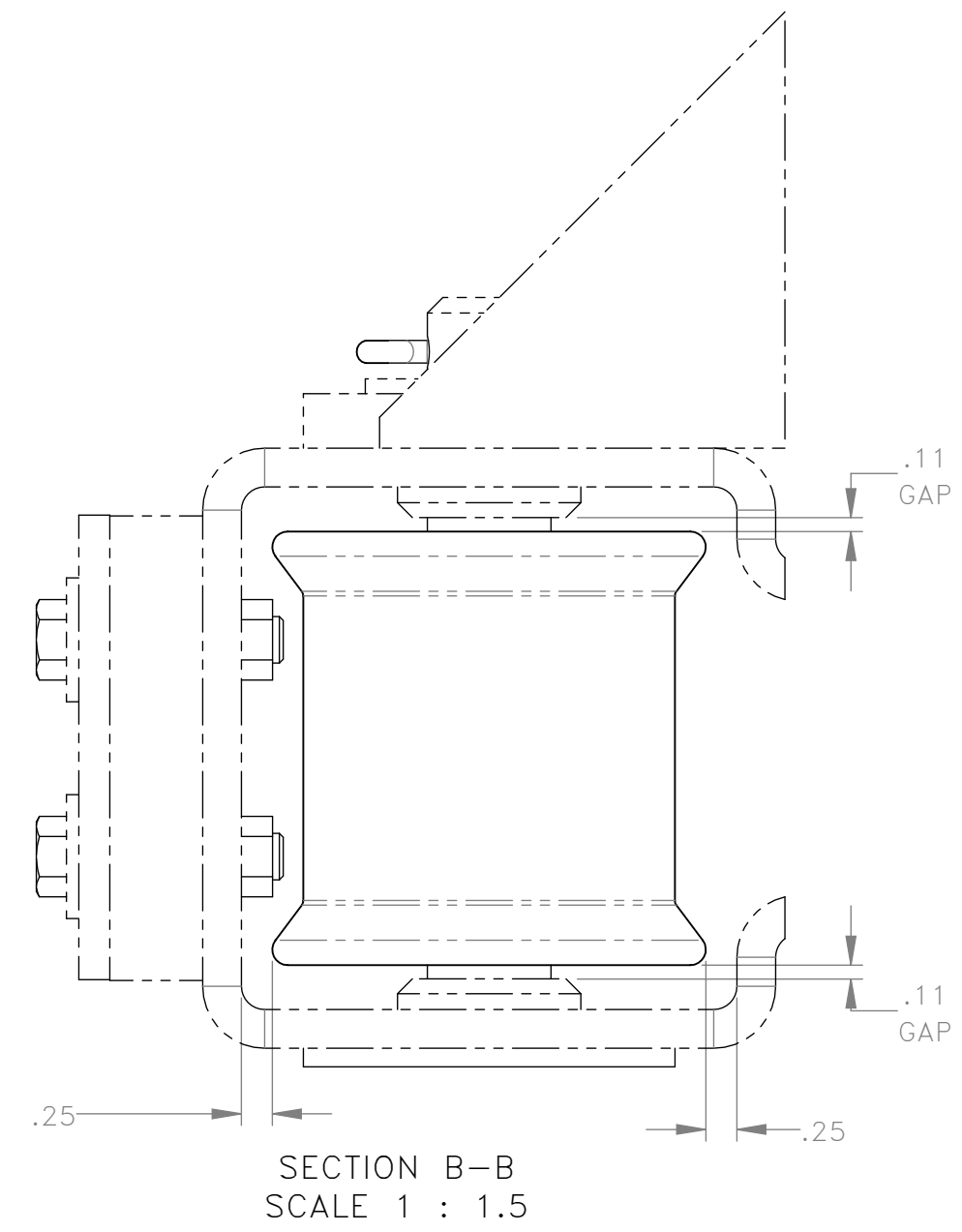
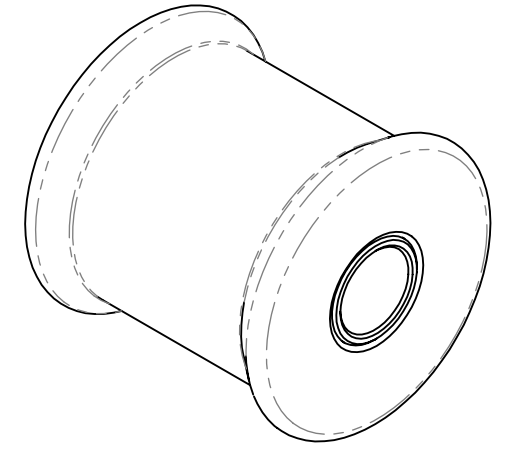
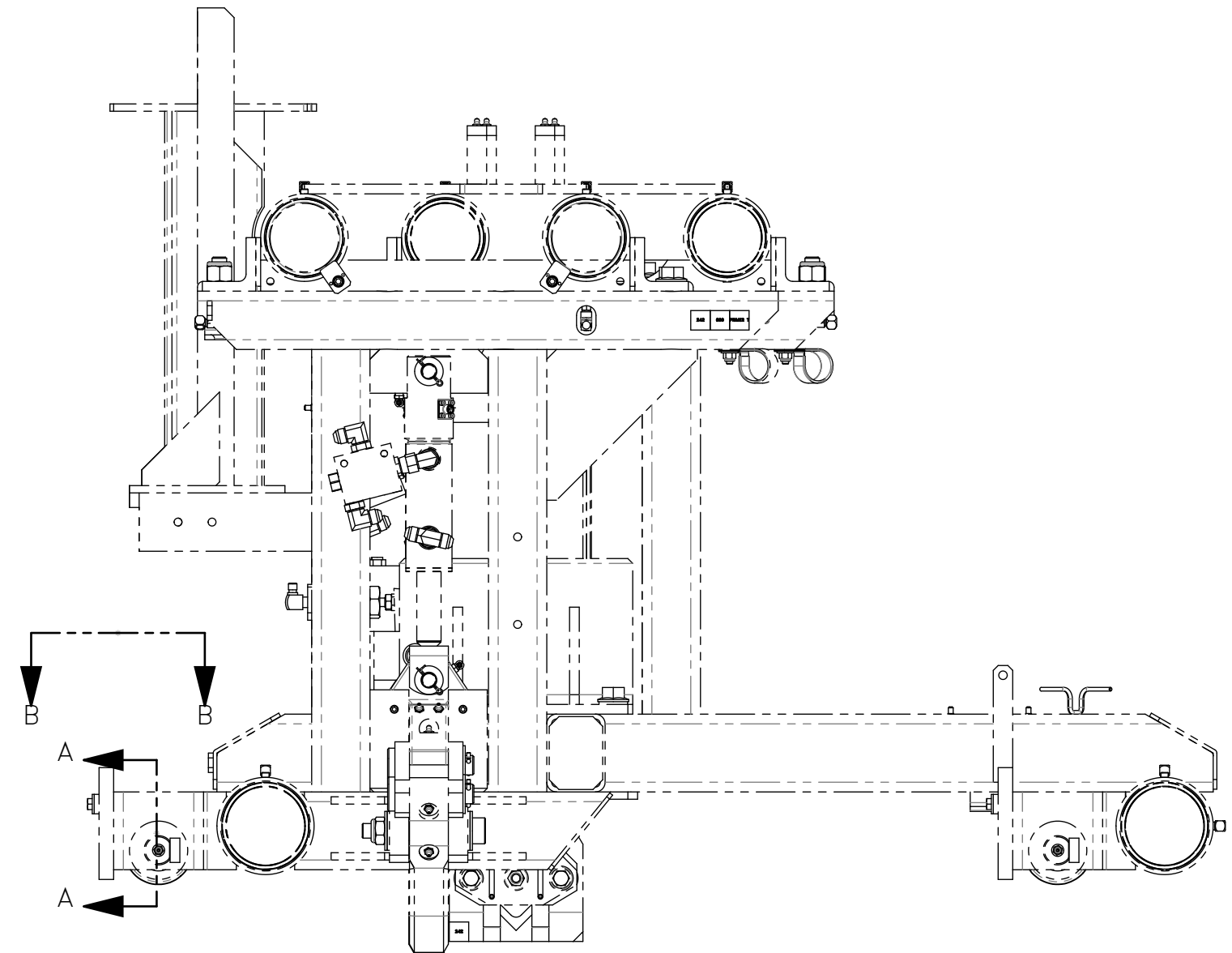
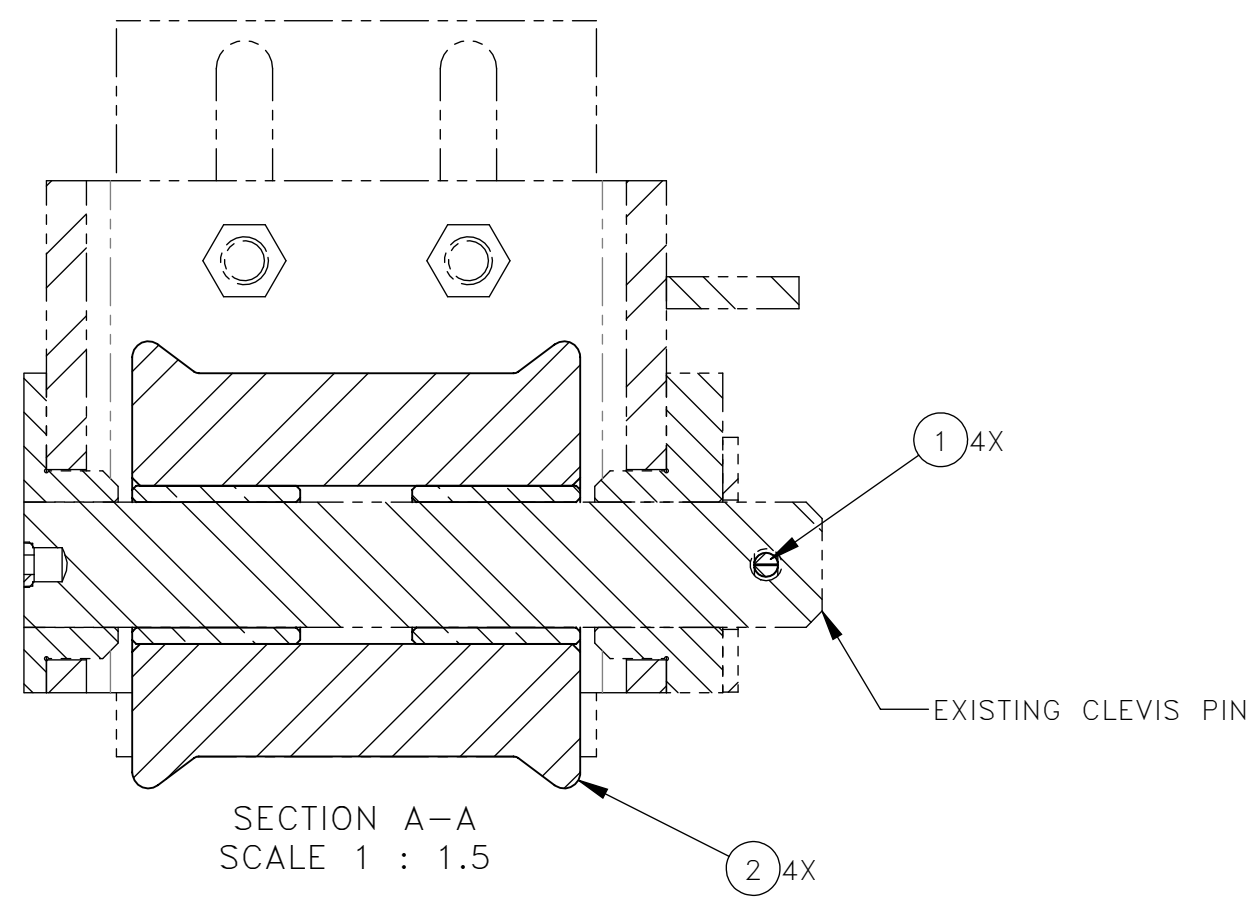

REV	EN	DESCRIPTION	DATE	DRN
1	5901	NEW RELEASE	9-21	ML

DIMENSION TOLERANCES UNLESS OTHERWISE SPECIFIED

LINEAR	.XX=±.03	.XXX=±.010
ANGULAR	X°=±1°	X.X°=±.5°

SURFACE FINISH 125 ✓ SMOOTH ALL SHARP EDGES
NOT TO EXCEED CLEAN ALL WELDS

THIS PRINT AND ALL INFORMATION WITHIN
BELONGS TO RACINE RAILROAD PRODUCTS

RACINE RAILROAD PRODUCTS
RACINE, WISCONSIN USA

DESCRIPTION
KIT, GUIDE ROLLER

MATERIAL
SEE BOM

USED ON	932587	SCALE	1:8	DATE	09-14-21
---------	--------	-------	-----	------	----------

DRN	ML	CHK	APP	JOB NO	RD150003	SHEET	1 OF 1
-----	----	-----	-----	--------	----------	-------	--------

DWG SIZE	C	CATALOG	K	DWG NO	793123
----------	---	---------	---	--------	--------