

IGNITION SWITCH
MAY BE IN EITHER LOCATION

LEFT CONTROL BOX

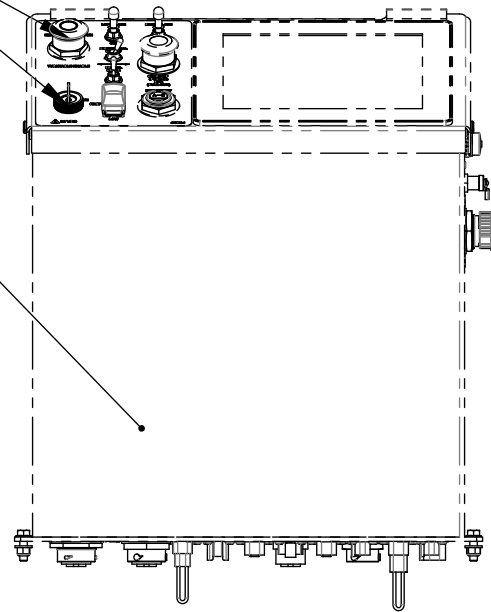

FOR INSTRUCTIONS SEE ITEM 2

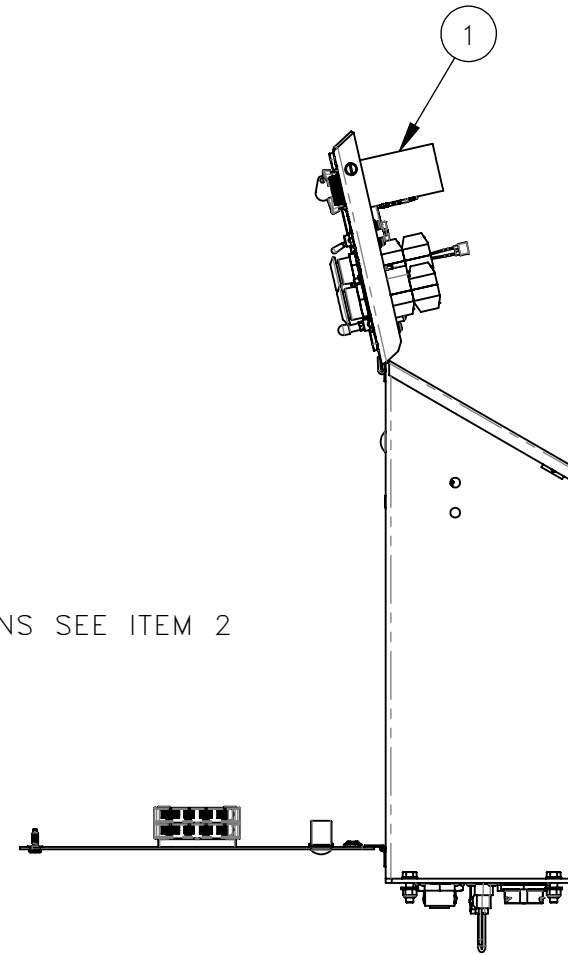

NO.	QTY	DESCRIPTION	PART NO.
1	1	TUBING, HEAT SHRINK W/ ADHESIVE	322999
2	1	INSTRUCTIONS, IGNITION SWITCH HEAT SHRINK KIT	800368

REV	EN	DESCRIPTION	DATE	DRN
1	5984	NEW RELEASE	10-21	PR
DIMENSION TOLERANCES UNLESS OTHERWISE SPECIFIED				
LINEAR		.XX=±.03	.XXX=±.010	
ANGULAR		X°=±1°	X.X°=±.5°	
SURFACE FINISH		125/√	SMOOTH ALL SHARP EDGES CLEAN ALL WELDS	
NOT TO EXCEED				
THIS PRINT AND ALL INFORMATION WITHIN BELONGS TO RACINE RAILROAD PRODUCTS				
RACINE RAILROAD PRODUCTS RACINE, WISCONSIN USA				
DESCRIPTION				
KIT, IGNITION SWITCH HEAT SHRINK				
MATERIAL				
SEE BOM				
USED ON			SCALE	DATE
718781 719477			1:8	10-28-21
DRN	CHK	APP	JOB NO	SHEET
PR			RD190005	1 OF 1
DWG SIZE		CATALOG	DWG NO	
B		K	793127	