

NO.	QTY.	DESCRIPTION	PART NO.
1	2	GUARD, BELT	323014
2	1	INSTRUCTIONS, CONVEYOR BELT GUARD KIT	800380

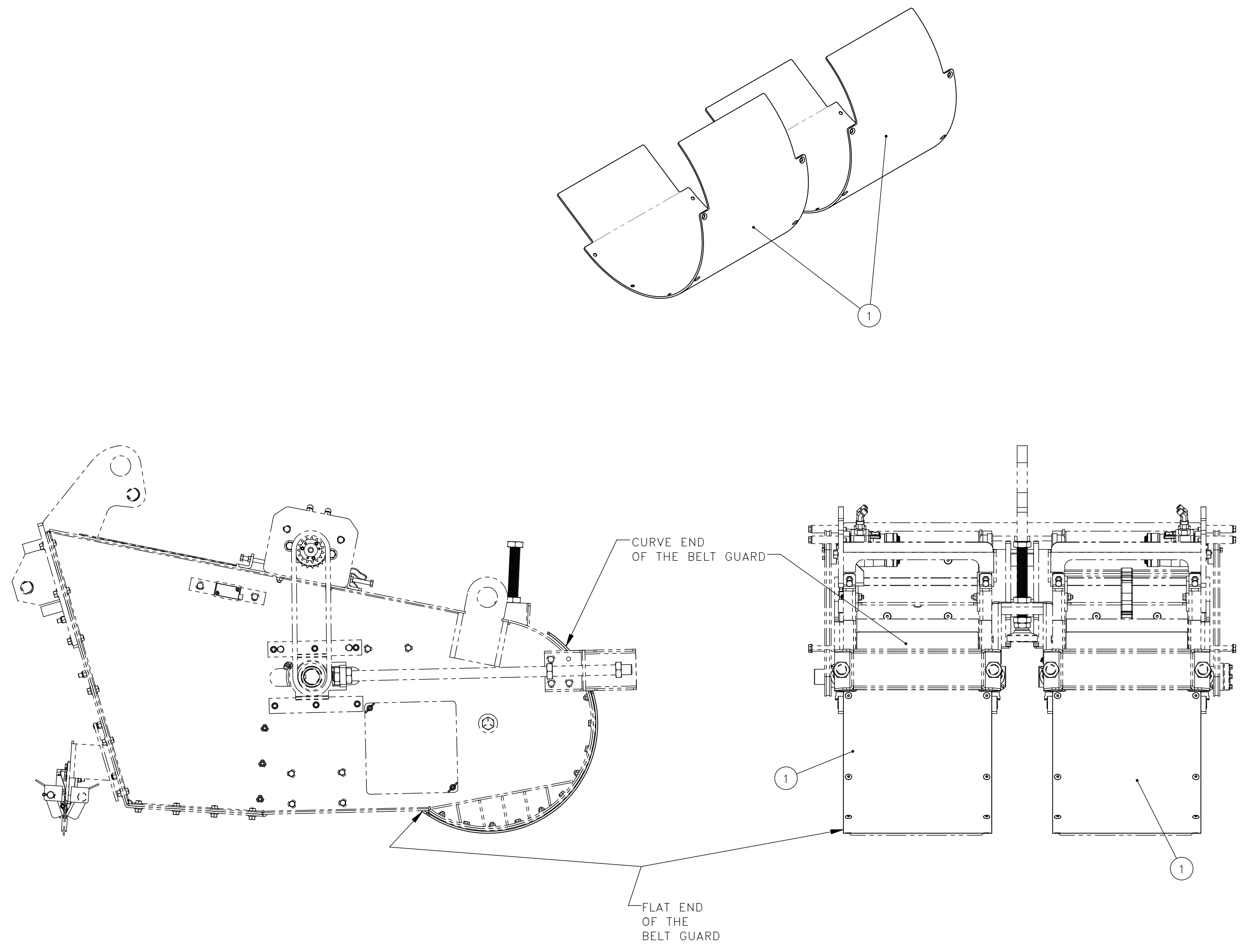

2 KITS REQUIRED PER MACHINE USED ON: 910197

REV	EN	DESCRIPTION	DATE	DRN
1	6071	NEW RELEASE	01-22	PR
DIMENSION TOLERANCES UNLESS OTHERWISE SPECIFIED				
LINEAR	.XX=±.03	.XXX=±.010		
ANGULAR	X°=±1°	X.X°=±.5°		
SURFACE FINISH NOT TO EXCEED		125/√	SMOOTH ALL SHARP EDGES CLEAN ALL WELDS	
THIS PRINT AND ALL INFORMATION WITHIN BELONGS TO RACINE RAILROAD PRODUCTS				
RACINE RAILROAD PRODUCTS				
RACINE, WISCONSIN USA				
DESCRIPTION				
KIT, CONVEYOR BELT GUARD				
MATERIAL				
SEE BOM				
USED ON		SCALE	DATE	
910197		1:8	01-07-22	
DRN	CHK	APP	JOB NO	SHEET
PR			RD180001	1 OF 1
DWG SIZE	CATALOG	DWG NO		
C	K	793134		