

NO.	QTY.	DESCRIPTION	PART NO.
1	2	PLATE, SUPPPORT	323079
2	1	INSTRUCTIONS, CONVEYOR MOTOR BRACKET	800381

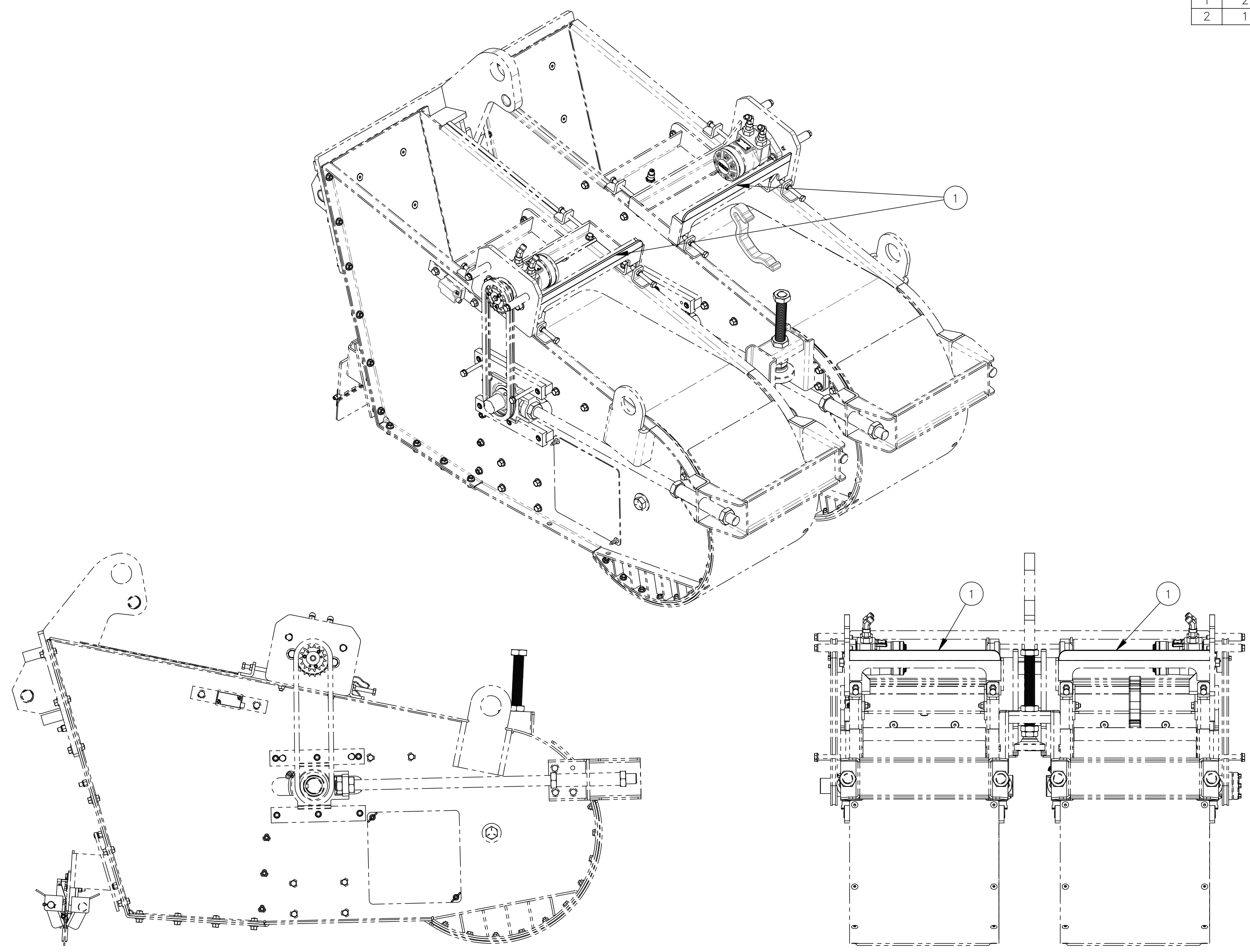

2 KITS REQUIRED PER MACHINE USED ON: 910197

REV	EN	DESCRIPTION	DATE	DRN
1	6071	NEW RELEASE	01-22	PR

DIMENSION TOLERANCES UNLESS OTHERWISE SPECIFIED

LINEAR	.XX=±.03	.XXX=±.010
ANGULAR	X°=±1°	X.X°=±.5°

SURFACE FINISH 125/√ SMOOTH ALL SHARP EDGES
NOT TO EXCEED CLEAN ALL WELDS

THIS PRINT AND ALL INFORMATION WITHIN BELONGS TO RACINE RAILROAD PRODUCTS

RACINE RAILROAD PRODUCTS
RACINE, WISCONSIN USA

DESCRIPTION
KIT, CONVEYOR MOTOR BRACKET

MATERIAL
SEE BOM

USED ON	SCALE	DATE
910197	1:8	01-07-22

DRN	CHK	APP	JOB NO	SHEET
PR			RD180001	1 OF 1

DWG SIZE	CATALOG	DWG NO
C	K	793135