

NO.	QTY	DESCRIPTION	PART NO.
1	1	PLATE, PUSH	324366
2	1	INSTRUCTIONS, SMALL PLATE CLAMP: PLATE, PUSH	800419

DWG NO
793203

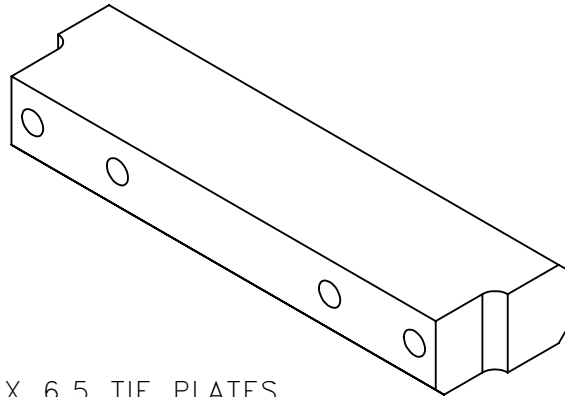

NOTE:
FOR USE WITH SMALL 9 X 6.5 TIE PLATES

2 KITS REQUIRED PER MACHINE

USED ON:
720136 & 720484 PLATE CLAMP MECHANISMS

FOR USE WITH 931587 & 932587 PLATE CENTERING ATPI MACHINES

REV	EN	DESCRIPTION	DATE	DRN
1	00392	NEW RELEASE	11-23	PMK

DIMENSION TOLERANCES UNLESS OTHERWISE SPECIFIED

LINEAR	.XX=±.03	.XXX=±.010	KERF ALLOW.
ANGULAR	X°=±1°	X.X°=±.5°	

SURFACE FINISH 125/ NOT TO EXCEED SMOOTH ALL SHARP EDGES CLEAN ALL WELDS

THIS PRINT AND ALL INFORMATION WITHIN BELONGS TO RACINE RAILROAD PRODUCTS

RACINE RAILROAD PRODUCTS

RACINE, WISCONSIN USA

DESCRIPTION
KIT, SMALL PLATE: 93X587

MATERIAL TYPE
SEE BOM

USED ON 932587, 931587	SCALE 1:2	DATE 11-09-23
---------------------------	--------------	------------------

DRN PMK	WEIGHT (LBS) 3.00	JOB NO RD150003	SHEET 1 OF 1
------------	----------------------	--------------------	-----------------

DWG SIZE A	CATALOG K	DWG NO 793203
----------------------	---------------------	-------------------------