

INSTRUCTIONS

REMOVE FORWARD HANDRAILS:

1. GRIND WELD FROM EACH HANDRAIL TO REMOVE, GRIND SURFACE FLUSH.

INSTALL SUPPLIED HANDRAILS:

1. POSITION HANDRAILS AS SHOWN, MARK HOLES IN CAB FRAME.
2. DRILL $\varnothing.28$ HOLES THROUGH CAB FRAME TUBE.
3. PRIME AND PAINT AREA, INSTALL HANDRAILS WITH SUPPLIED SELF-TAPPING SCREWS.

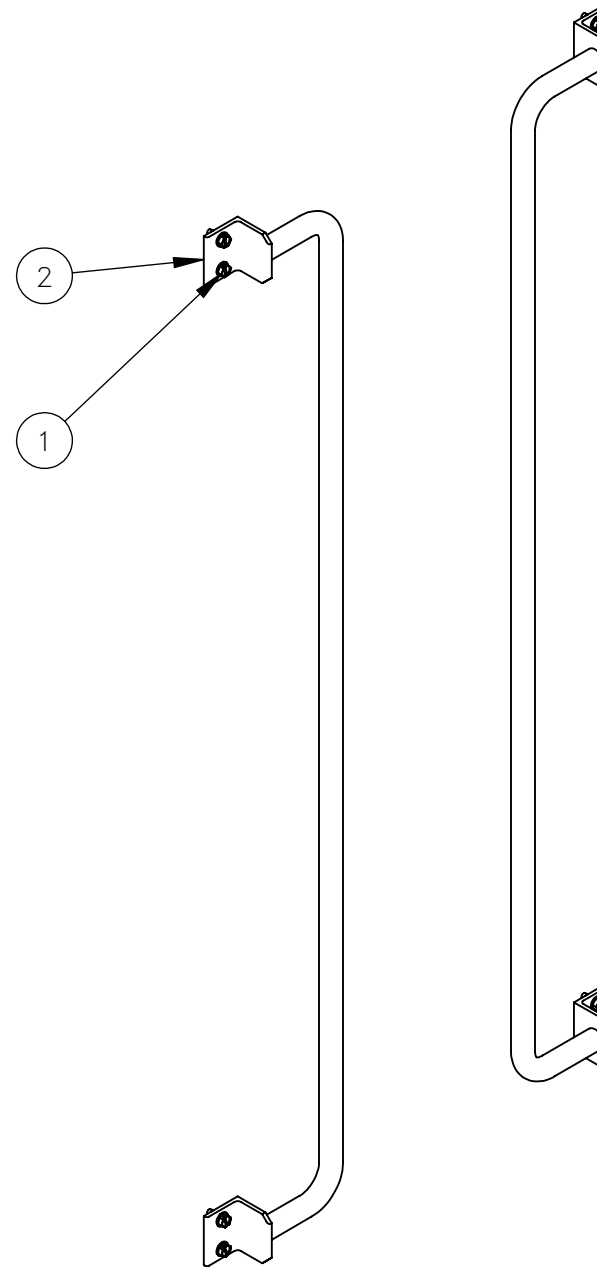
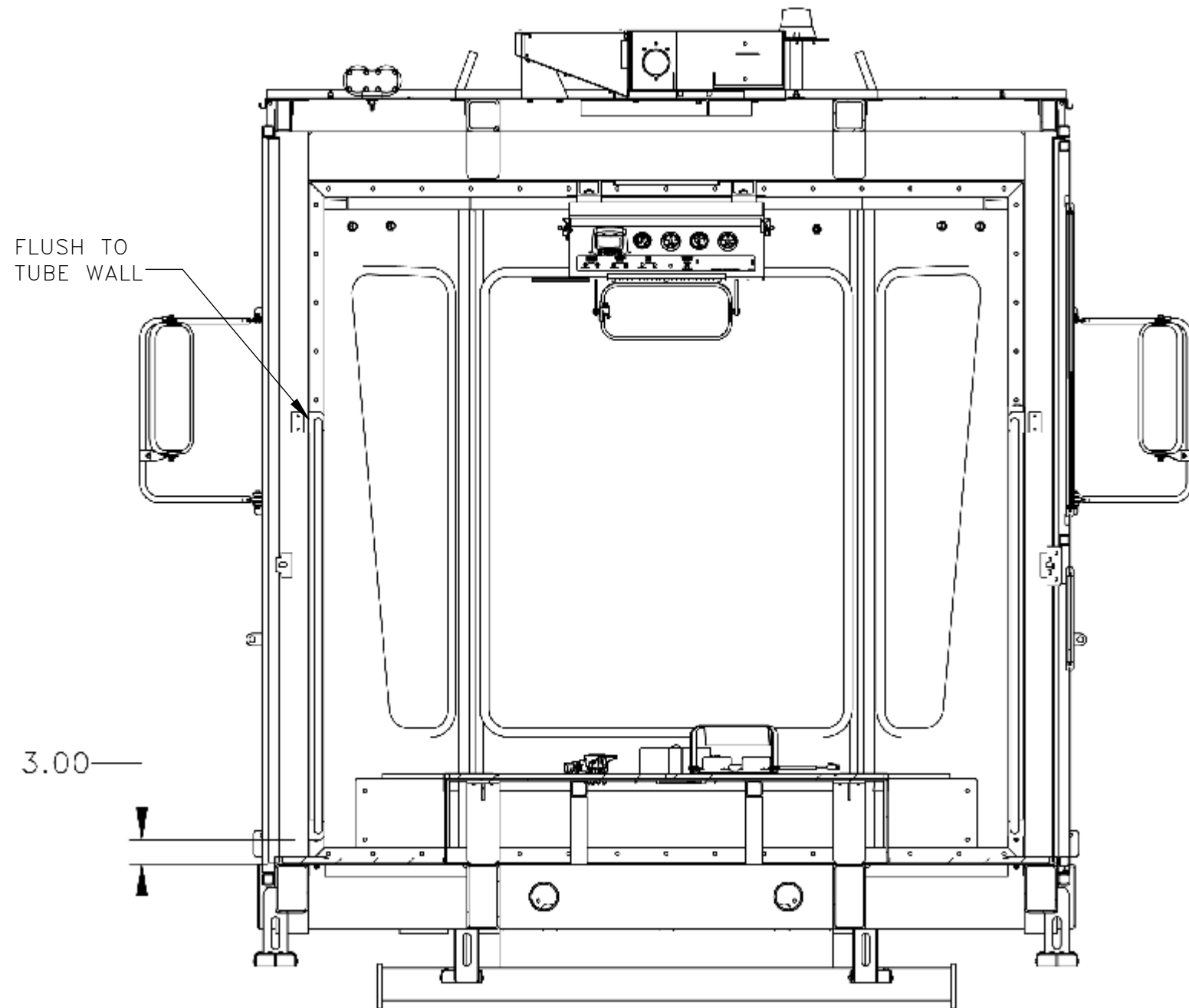

NO.	QTY	DESCRIPTION	PART NO.
1	REF	SCR, SEL TPG: .31-18 X .75	468063
2	REF	HANDRAIL	781355

REV	EN	DESCRIPTION	DATE	DRN
1	2949	NEW RELEASE	3-18	MSO
DIMENSION TOLERANCES UNLESS OTHERWISE SPECIFIED				
LINEAR		.XX=±.03	.XXX=±.010	
ANGULAR		X°=±1°	X.X°=±.5°	
SURFACE FINISH		125/	SMOOTH ALL SHARP EDGES	
NOT TO EXCEED			CLEAN ALL WELDS	
THIS PRINT AND ALL INFORMATION WITHIN BELONGS TO RACINE RAILROAD PRODUCTS				
RACINE RAILROAD PRODUCTS RACINE, WISCONSIN USA				
DESCRIPTION				
INSTRUCTIONS, HANDRAILS				
MATERIAL				
SEE BOM				
USED ON		793006	SCALE	DATE
			1:8	03-22-18
DRN	CHK	APP	JOB NO	SHEET
MSO			RD130002	1 OF 1
EXP NO			DWG NO	
			800269	