

INSTRUCTIONS:

- 1 OPEN COVER, REMOVE 3 UPPER SCREWS AND REMOVE COVER,
- 2 REMOVE LOWER 3 SCREWS AND REMOVE SHEET.
- 3 MARK AND DRILL HOLES IN COVER AND SHEET.
- 4 INSTALL ANGLE TO SHEET.
- 5 RE-INSTALL SHEET AND COVER IN CAB.
- 6 INSTALL BODY END OF THE GAS SPRING TO COVER, INSTALL ROD END TO THE ANGLE.
- 7 CLOSE AND LATCH COVER.

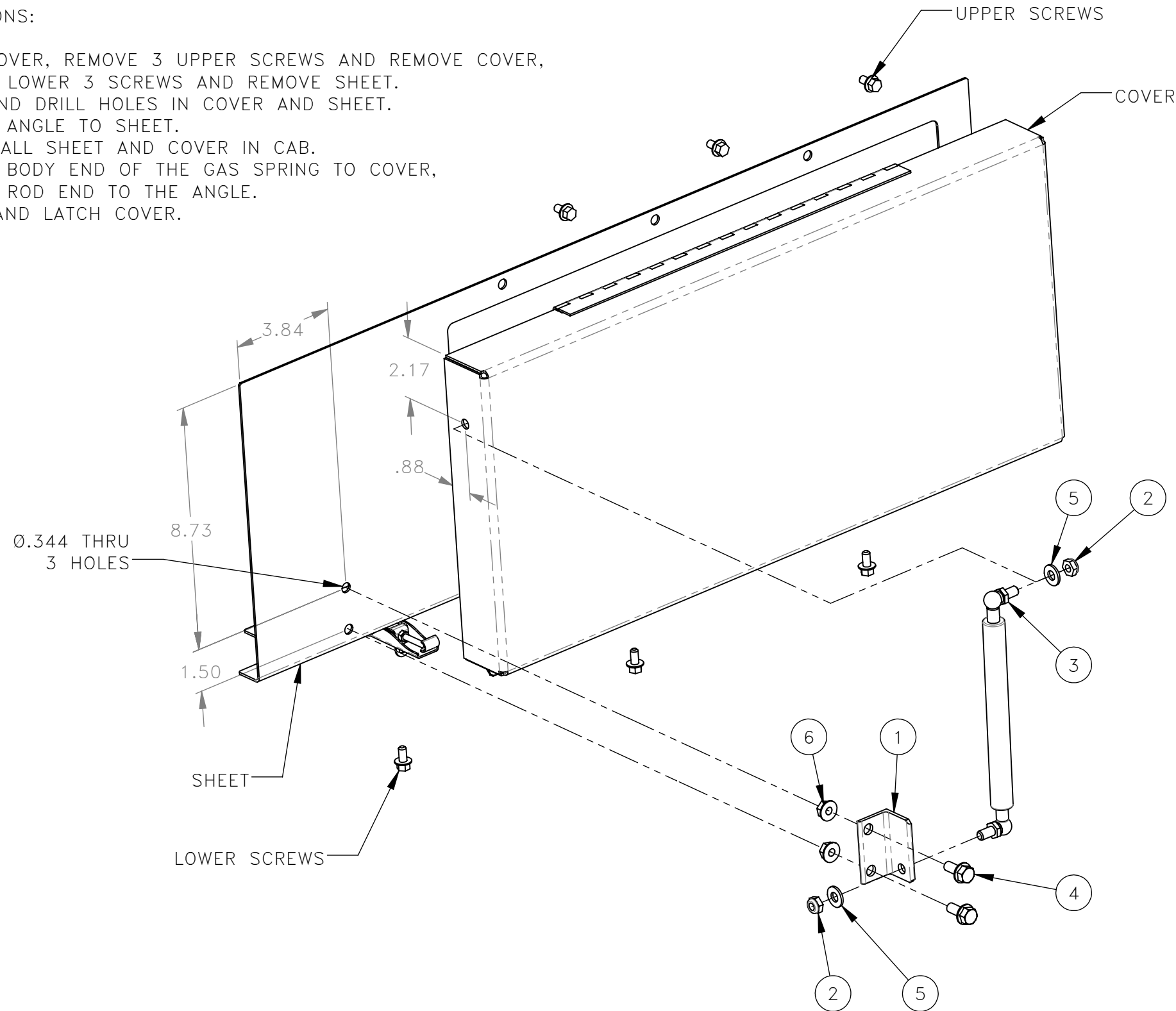

NO.	QTY	DESCRIPTION	PART NO.
1	REF	ANGLE	318490
2	REF	NUT, HEX ES JAM: .31-18	404141
3	REF	SPRING, GAS	473281
4	REF	SCR, HEX FLG: .31-18 X .75	491045
5	REF	WASHER, FLT: .31	491259
6	REF	NUT, HEX FLG: .31-18	491331

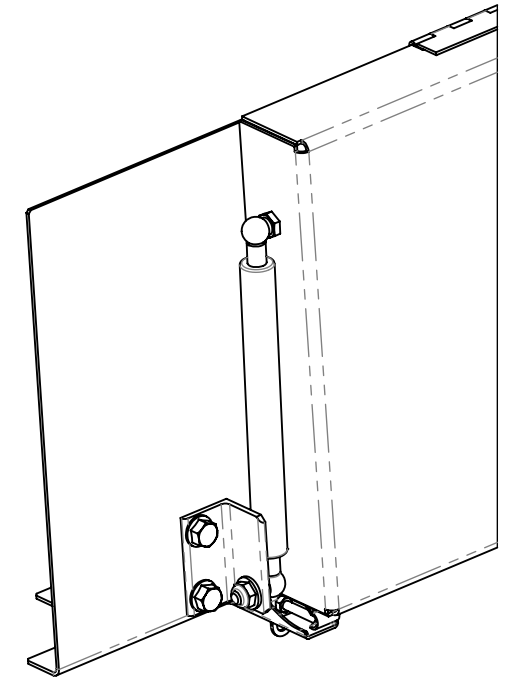

REV	EN	DESCRIPTION	DATE	DRN
1	3010	NEW RELEASE	3-18	MSO
DIMENSION TOLERANCES UNLESS OTHERWISE SPECIFIED				
LINEAR	.XX=±.03	.XXX=±.010		
ANGULAR	X°=±1°	X.X°=±.5°		
SURFACE FINISH		125 ✓	SMOOTH ALL SHARP EDGES CLEAN ALL WELDS	
NOT TO EXCEED				
THIS PRINT AND ALL INFORMATION WITHIN BELONGS TO RACINE RAILROAD PRODUCTS				
<b>RACINE RAILROAD PRODUCTS</b> RACINE, WISCONSIN USA				
DESCRIPTION				
INSTRUCTIONS, COVER PROP				
MATERIAL				
SEE BOM				
USED ON		793007	SCALE	DATE
			1:4	03-23-18
DRN	CHK	APP	JOB NO	SHEET
MSO			RD150003	1 OF 1
EXP NO			DWG NO	
			800270	