

INSTRUCTIONS:

1. LOCATE PLACARDS AS SHOWN, WITH A #37 (.104) DRILL BIT, TRANSFER HOLES THROUGH PLACARDS 3/8" DEEP AND INSTALL DRIVE SCREWS.
2. REPEAT ON OPPOSITE WORKHEAD.

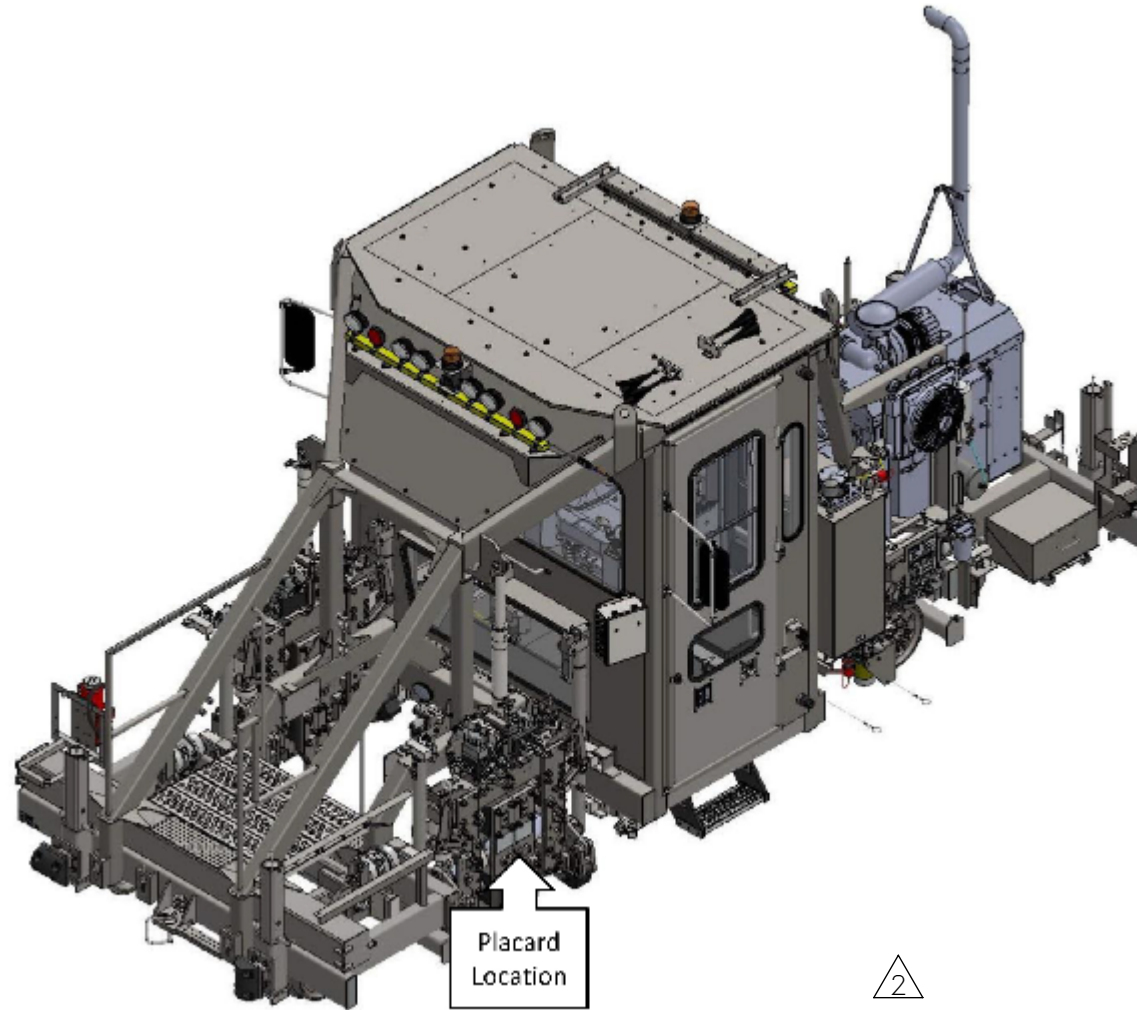

NO.	QTY	DESCRIPTION	PART NO.
1	REF	PLACARD, .75 FASTENER TORQUE	473293
2	REF	PLACARD, .38 FASTENER TORQUE	473295
3	REF	SCR, DRIVE: #4 X .25	491673

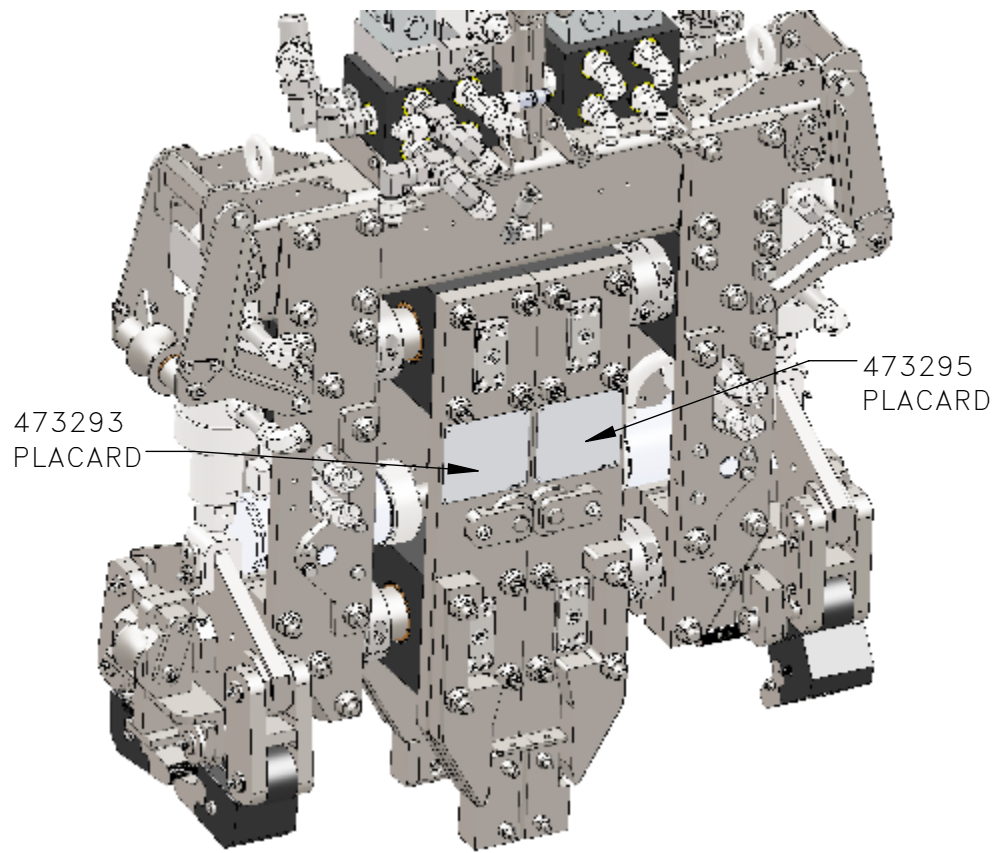
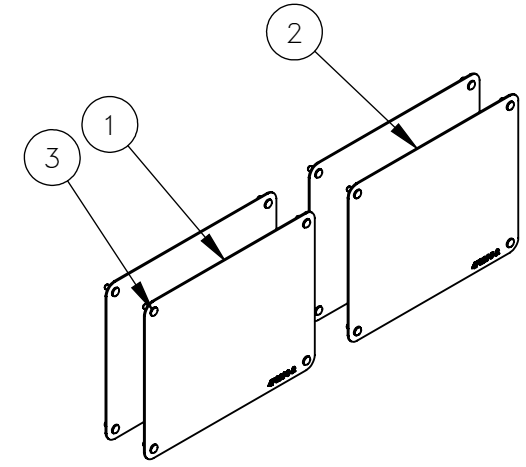

NOTE:
 FOR USE WITH COMBO DAS MACHINES
 913569, 914569, 931569, 933569

REV	EN	DESCRIPTION	DATE	DRN
1	3082	NEW RELEASE	4-18	MSO
2	3635	UPDATED PICTORIAL, ADDED NOTE	10-18	MSO

DIMENSION TOLERANCES UNLESS OTHERWISE SPECIFIED

LINEAR	.XX=±.03	.XXX=±.010
ANGULAR	X°=±1°	X.X°=±.5°

SURFACE FINISH 125 ✓ NOT TO EXCEED
 SMOOTH ALL SHARP EDGES
 CLEAN ALL WELDS

THIS PRINT AND ALL INFORMATION WITHIN BELONGS TO RACINE RAILROAD PRODUCTS

RACINE RAILROAD PRODUCTS
 RACINE, WISCONSIN USA

DESCRIPTION
 INSTRUCTIONS, FASTENER TORQUE
 PLACARDS (DAS)

MATERIAL
 SEE BOM

USED ON	793015	SCALE	1:4	DATE	04-19-18
DRN	MSO	CHK	APP	JOB NO	RD140001
EXP NO				SHEET	1 OF 1
				DWG NO	800275