

NO.	QTY	DESCRIPTION	PART NO.
1	REF	PLACARD, FASTENER TORQUE	473292
2	REF	SCR, DRIVE: #4 X .25	491673

DWG NO
800276

INSTRUCTIONS:

1. LOCATE PLACARDS AS SHOWN, WITH A #37 (.104) DRILL BIT, **TRANSFER HOLES THROUGH PLACARDS 3/8" DEEP** AND INSTALL DRIVE SCREWS.
2. REPEAT ON OPPOSITE WORKHEAD.

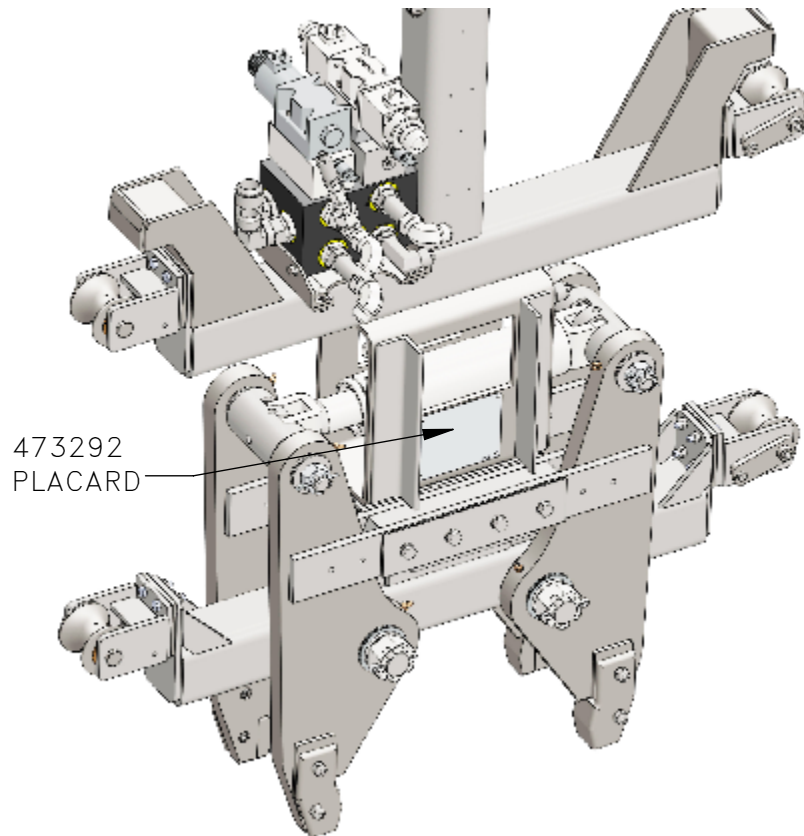
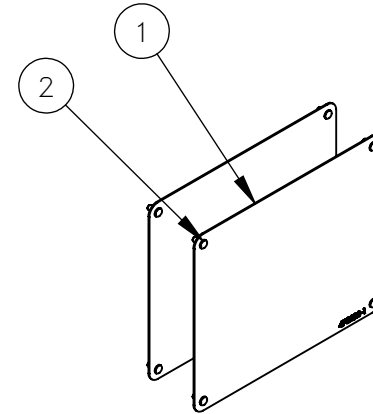

REV	EN	DESCRIPTION	DATE	DRN
1	3082	NEW RELEASE	4-18	MSO
DIMENSION TOLERANCES UNLESS OTHERWISE SPECIFIED				
LINEAR	.XX=±.03	.XXX=±.010		
ANGULAR	X°=±1°	X.X°=±.5°		
SURFACE FINISH 125/		SMOOTH ALL SHARP EDGES		
NOT TO EXCEED		CLEAN ALL WELDS		
THIS PRINT AND ALL INFORMATION WITHIN BELONGS TO RACINE RAILROAD PRODUCTS				
RACINE RAILROAD PRODUCTS				
RACINE, WISCONSIN USA				
DESCRIPTION				
INSTRUCTIONS, FASTENER TORQUE PLACARDS (DAA)				
MATERIAL				
SEE BOM				
USED ON			SCALE	DATE
			1:4	04-19-18
DRN	CHK	APP	JOB NO	SHEET
MSO			RD140001	1 OF 1
EXP NO			DWG NO	
			800276	