

NO.	QTY	DESCRIPTION	PART NO.
1	REF	HANDRAIL, 20.75 LONG	310345
2	REF	FLAT, STEP SUPPORT	314485
3	REF	CAP, HANDRAIL	314958
4	REF	TUBE, HANDLE	317296
5	REF	STEP	318833
6	REF	FLAT	318838
7	REF	STEP	718002

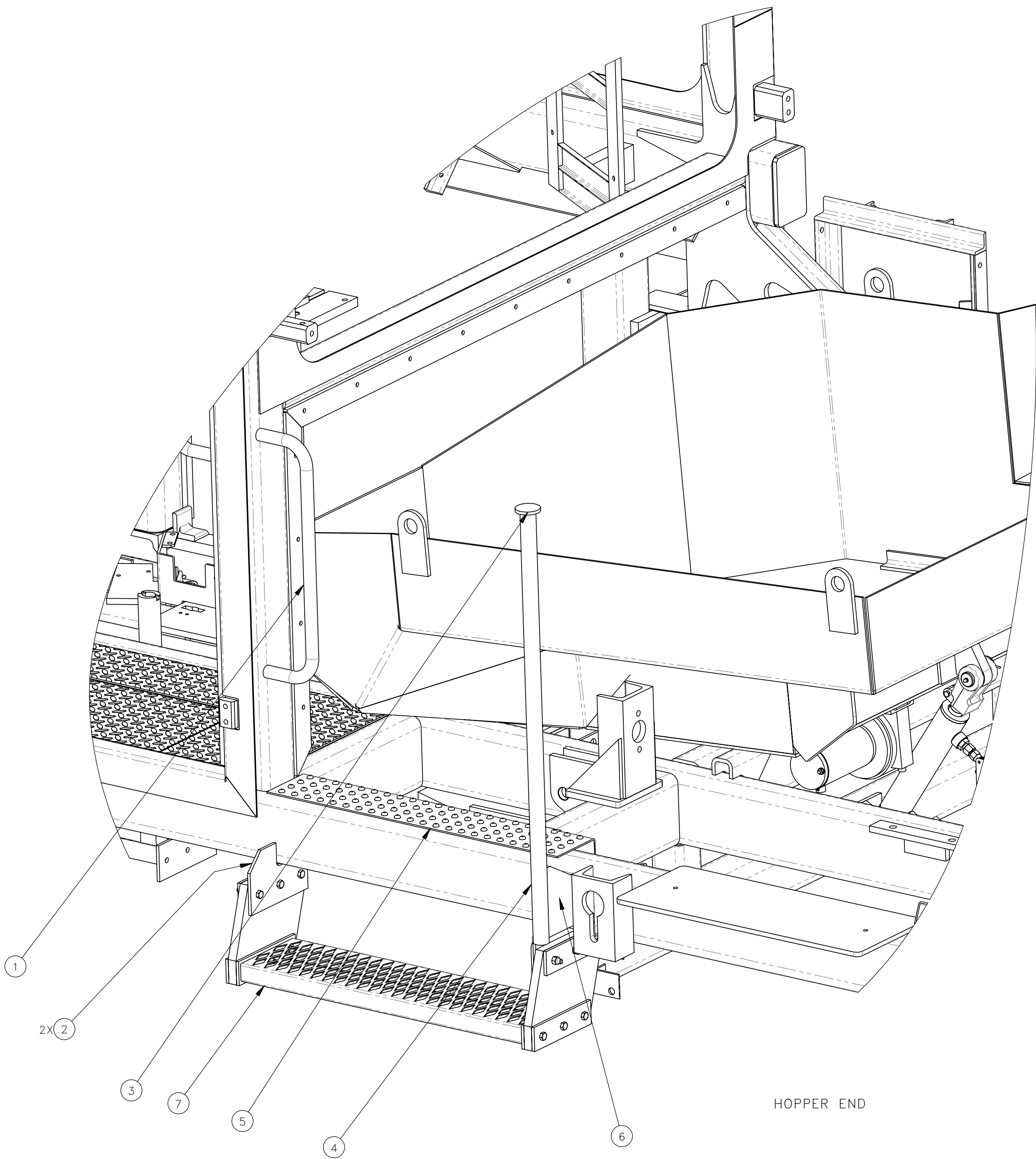

HOPPER END

REV	EN	DESCRIPTION	DATE	DRN
1	3154	NEW RELEASE	5-18	MAE

DIMENSION TOLERANCES UNLESS OTHERWISE SPECIFIED

LINEAR	.XX=±.03	.XXX=±.010
ANGULAR	X°=±1°	X.X°=±.5°

SURFACE FINISH 125 ✓ / NOT TO EXCEED SMOOTH ALL SHARP EDGES CLEAN ALL WELDS

THIS PRINT AND ALL INFORMATION WITHIN BELONGS TO RACINE RAILROAD PRODUCTS

**RACINE RAILROAD PRODUCTS**  
RACINE, WISCONSIN USA

DESCRIPTION  
INSTRUCTIONS: HOPPER EGRESS

MATERIAL  
SEE BOM

USED ON	793025	SCALE	1:6	DATE	05-14-18
---------	--------	-------	-----	------	----------

DRN	ME	CHK	APP	JOB NO	RD150002	SHEET	1 OF 3
-----	----	-----	-----	--------	----------	-------	--------

EXP NO		DWG NO	800285
--------	--	--------	--------

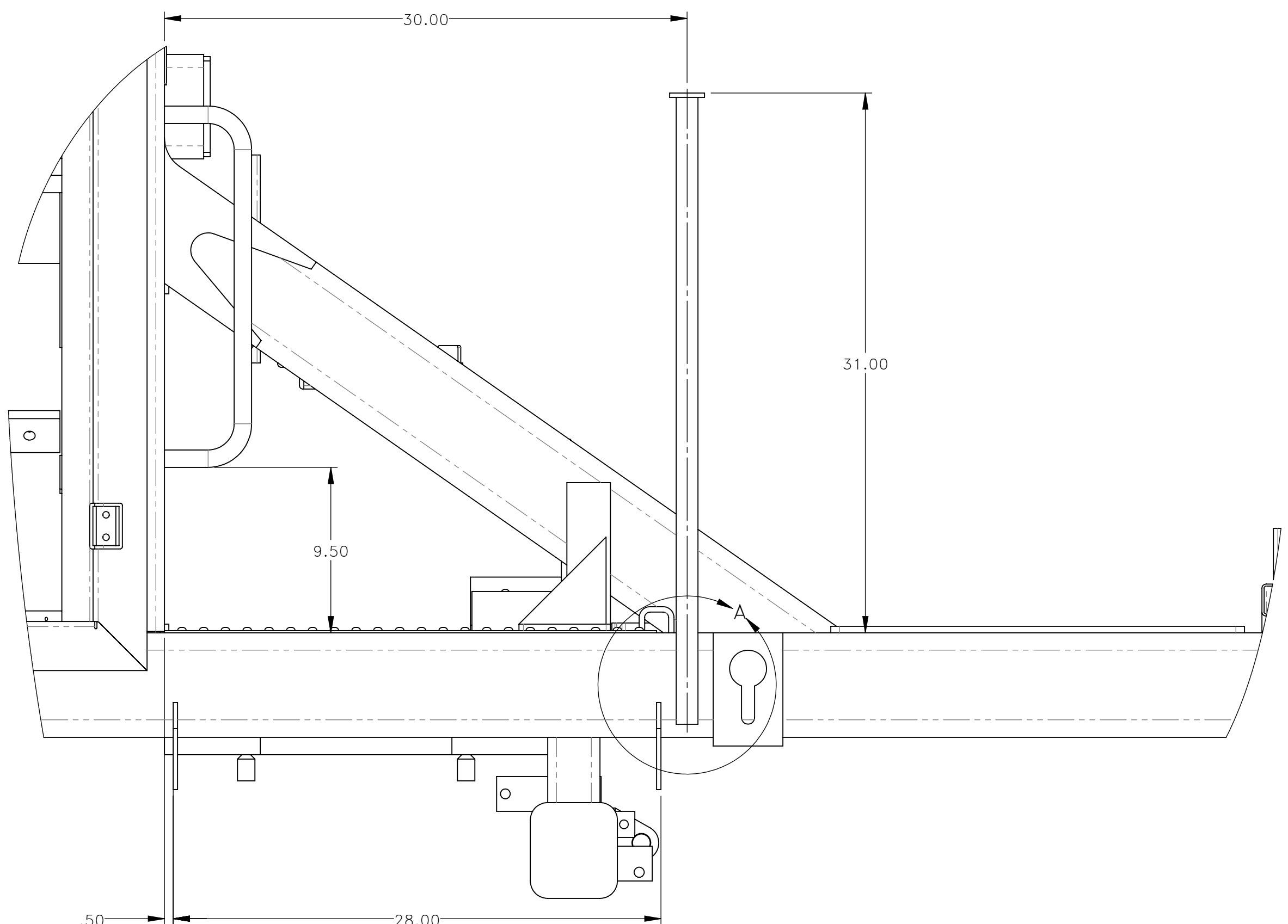
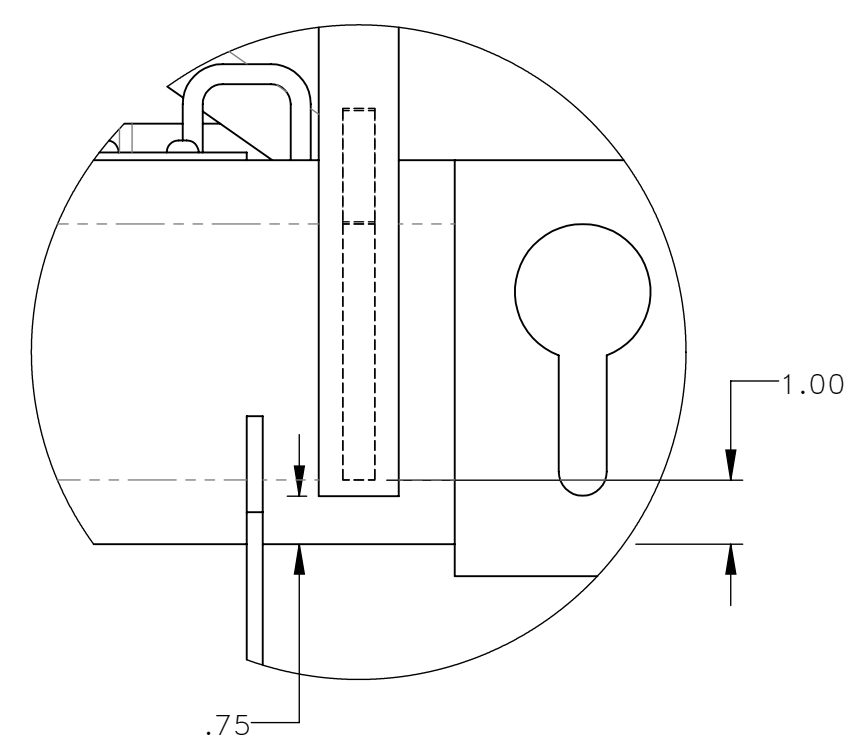
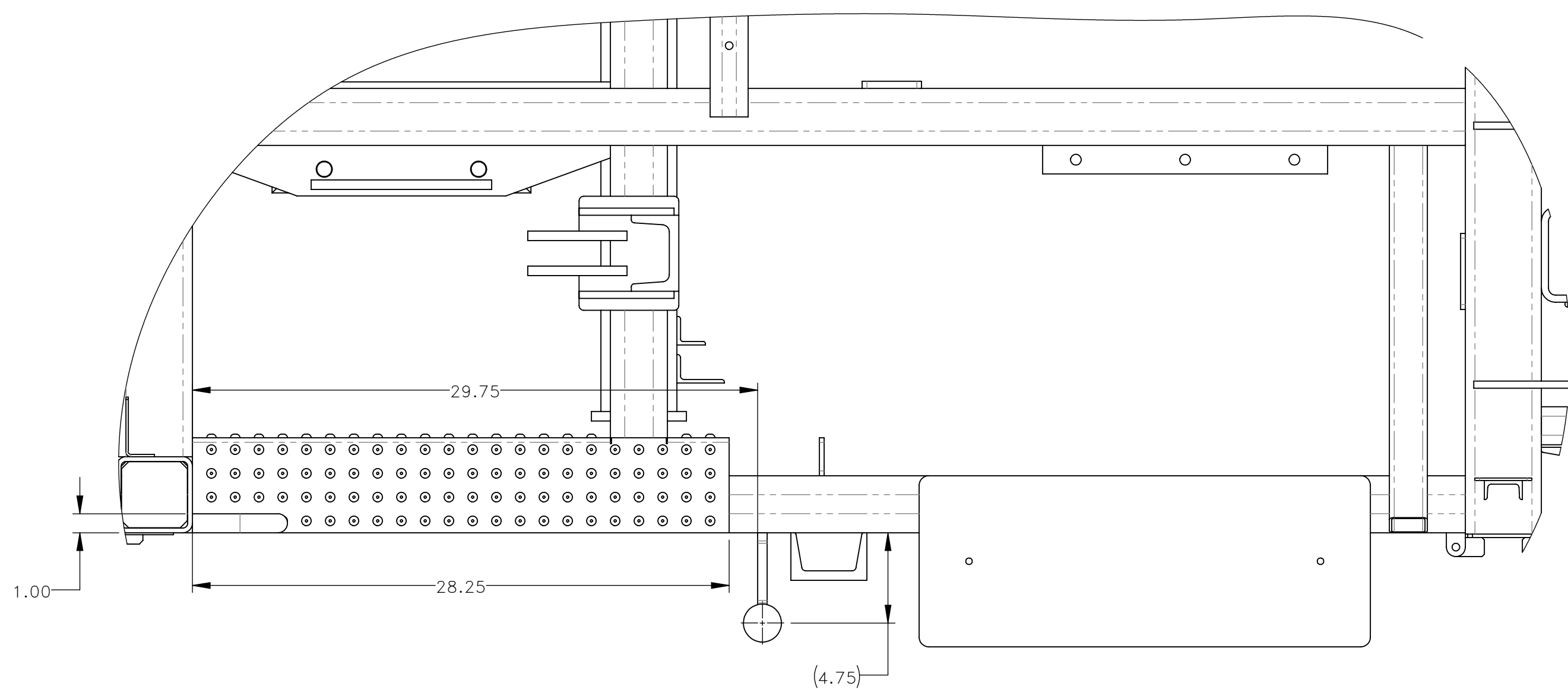

LOCATION OF PARTS

REV	EN	DESCRIPTION	DATE	DRN
1	3154	NEW RELEASE	5-18	MAE
DIMENSION TOLERANCES UNLESS OTHERWISE SPECIFIED				
LINEAR	.XX=±.03	.XXX=±.010		
ANGULAR	X°=±1°	X.X°=±.5°		
SURFACE FINISH NOT TO EXCEED	125 ✓	SMOOTH ALL SHARP EDGES CLEAN ALL WELDS		
THIS PRINT AND ALL INFORMATION WITHIN BELONGS TO RACINE RAILROAD PRODUCTS				
<b>RACINE RAILROAD PRODUCTS</b> RACINE, WISCONSIN USA				
DESCRIPTION INSTRUCTIONS: HOPPER EGRESS				
MATERIAL SEE BOM				
USED ON	793025	SCALE 1:6	DATE 05-14-18	
DRN	ME	CHK	APP	JOB NO RD150002
EXP NO				SHEET 2 OF 3
				DWG NO 800285

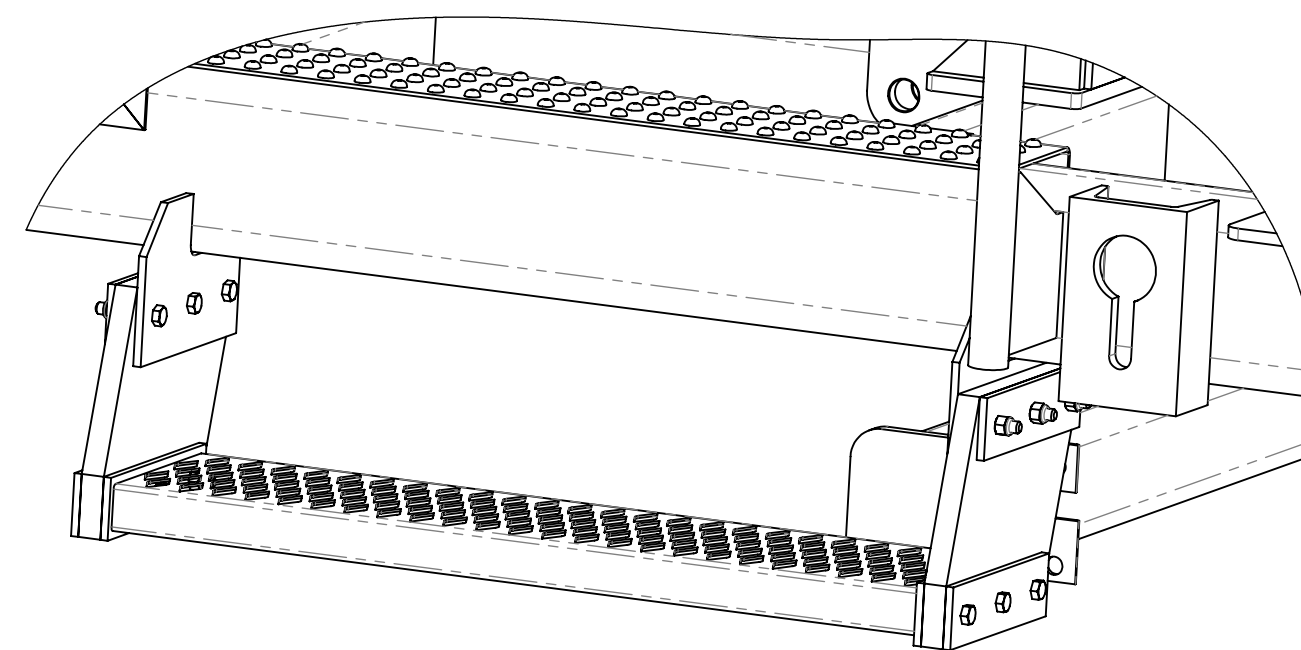
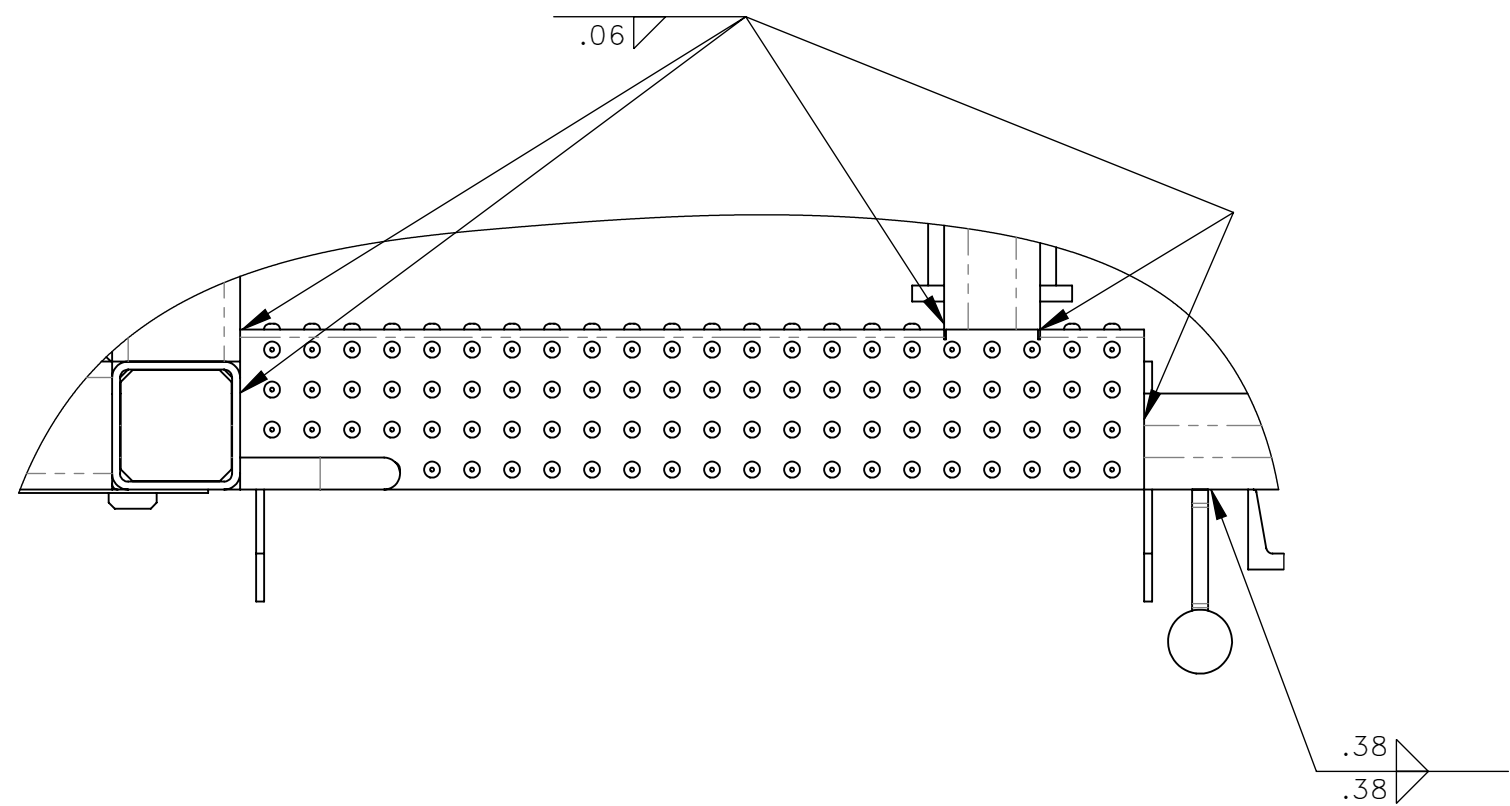

INSTALL STEP (718002) AS SHOWN

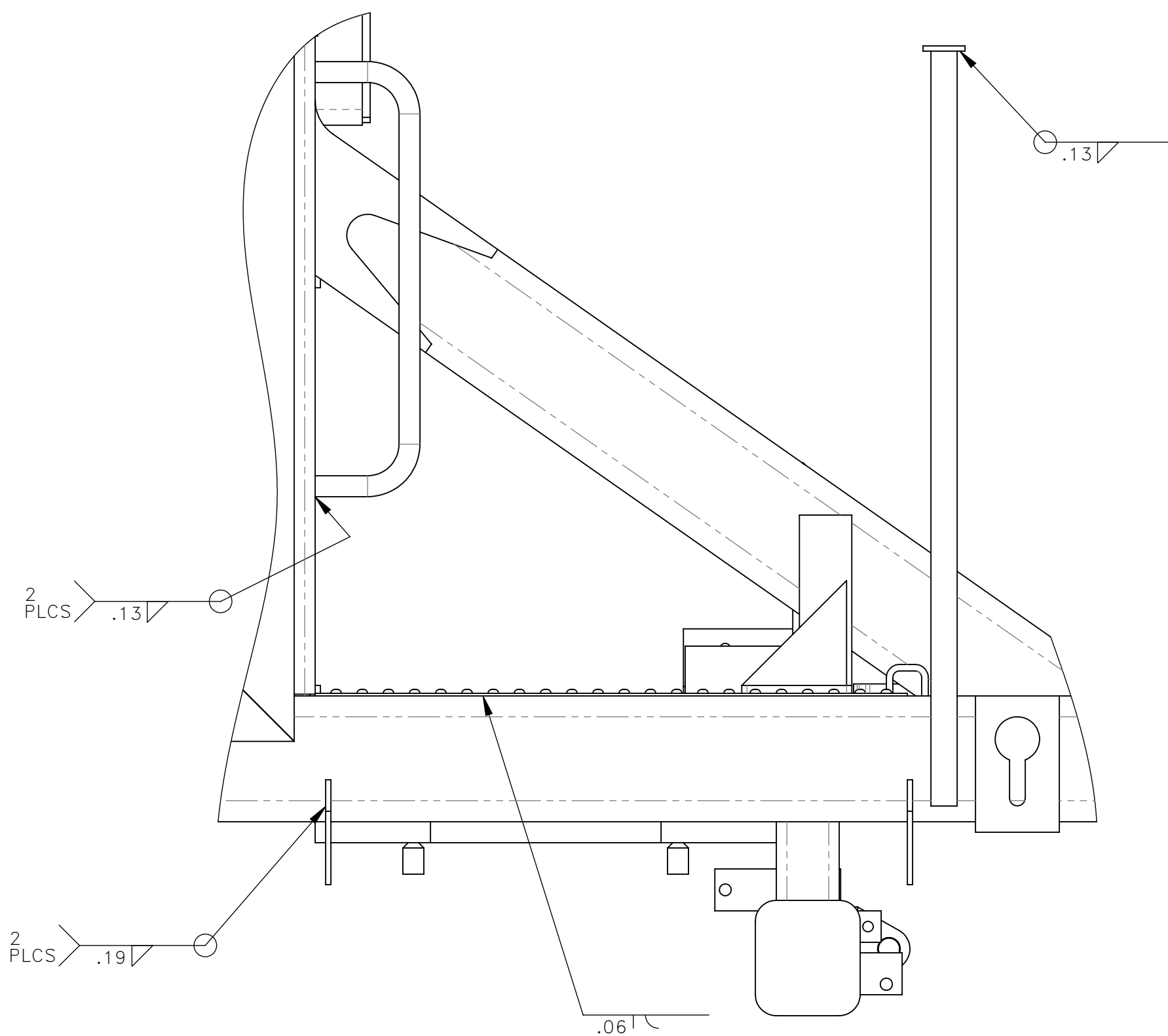

REV	EN	DESCRIPTION	DATE	DRN
1	3154	NEW RELEASE	5-18	MAE
DIMENSION TOLERANCES UNLESS OTHERWISE SPECIFIED				
LINEAR	.XX=±.03	.XXX=±.010		
ANGULAR	X°=±1°	X.X°=±.5°		
SURFACE FINISH NOT TO EXCEED	125 ✓	SMOOTH ALL SHARP EDGES CLEAN ALL WELDS		
THIS PRINT AND ALL INFORMATION WITHIN BELONGS TO RACINE RAILROAD PRODUCTS				
<b>RACINE RAILROAD PRODUCTS</b>				
RACINE, WISCONSIN USA				
DESCRIPTION				
INSTRUCTIONS: HOPPER EGRESS				
MATERIAL				
SEE BOM				
USED ON	793025	SCALE	DATE	
		1:6	05-14-18	
DRN	CHK	APP	JOB NO	SHEET
ME			RD150002	3 OF 3
EXP NO			DWG NO	
				800285