

NO.	QTY	DESCRIPTION	PART NO.
1	REF	CHANNEL	318861
2	REF	MIRROR, 12 CONVEX	465527

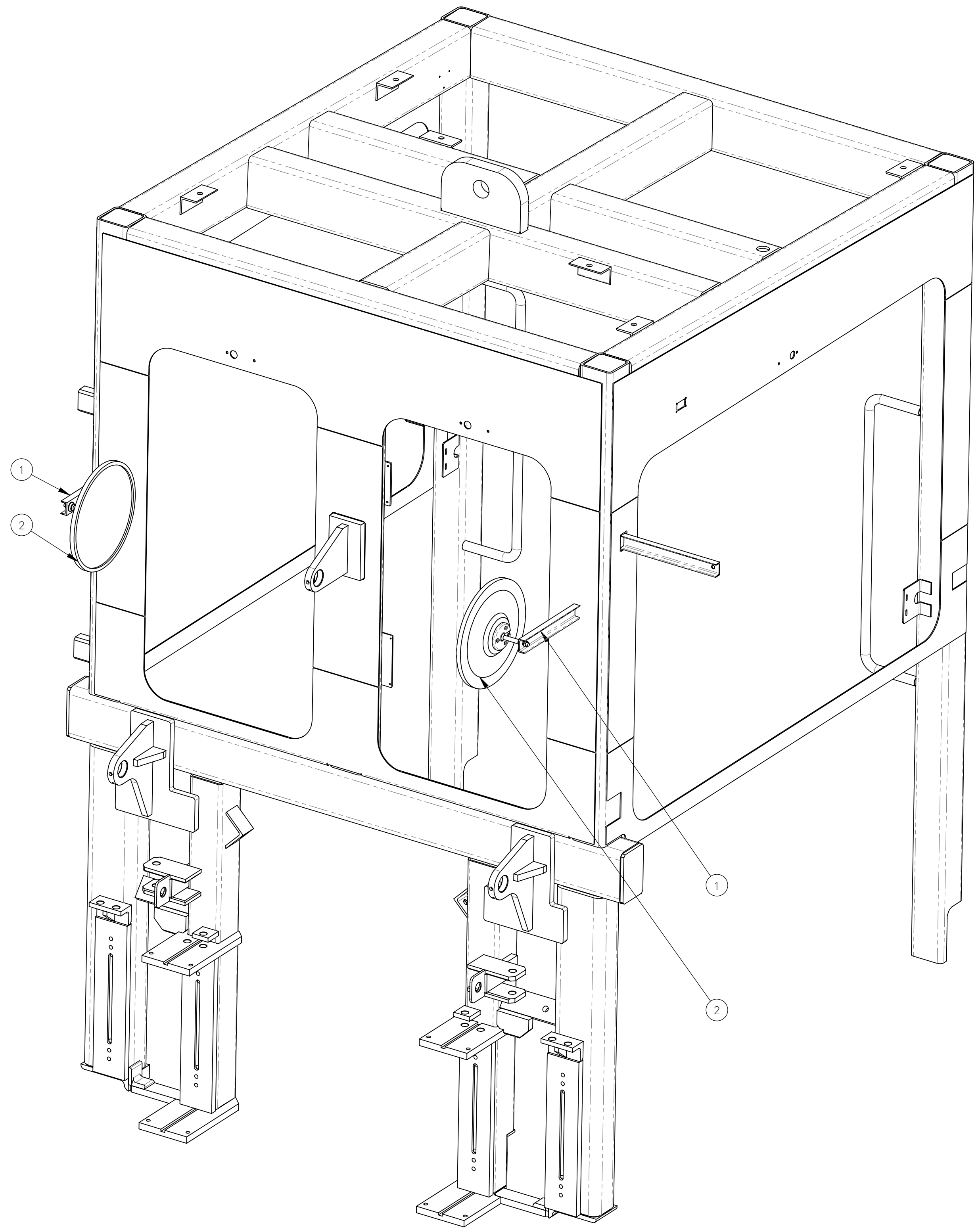

REV	EN	DESCRIPTION	DATE	DRN
1	3185	NEW RELEASE	5-18	MAE

DIMENSION TOLERANCES UNLESS OTHERWISE SPECIFIED

LINEAR	.XX=±.03	.XXX=±.010
ANGULAR	X°=±1°	X.X°=±.5°

SURFACE FINISH 125 ✓ SMOOTH ALL SHARP EDGES  
NOT TO EXCEED CLEAN ALL WELDS

THIS PRINT AND ALL INFORMATION WITHIN  
BELONGS TO RACINE RAILROAD PRODUCTS

**RACINE RAILROAD PRODUCTS**

RACINE, WISCONSIN USA

DESCRIPTION  
INSTRUCTIONS, MIRROR KIT

MATERIAL  
SEE BOM

USED ON	SCALE	DATE
793026	1:8	05-25-18

DRN	CHK	APP	JOB NO	SHEET
ME			RD150002	1 OF 2

EXP NO	DWG NO
	800286

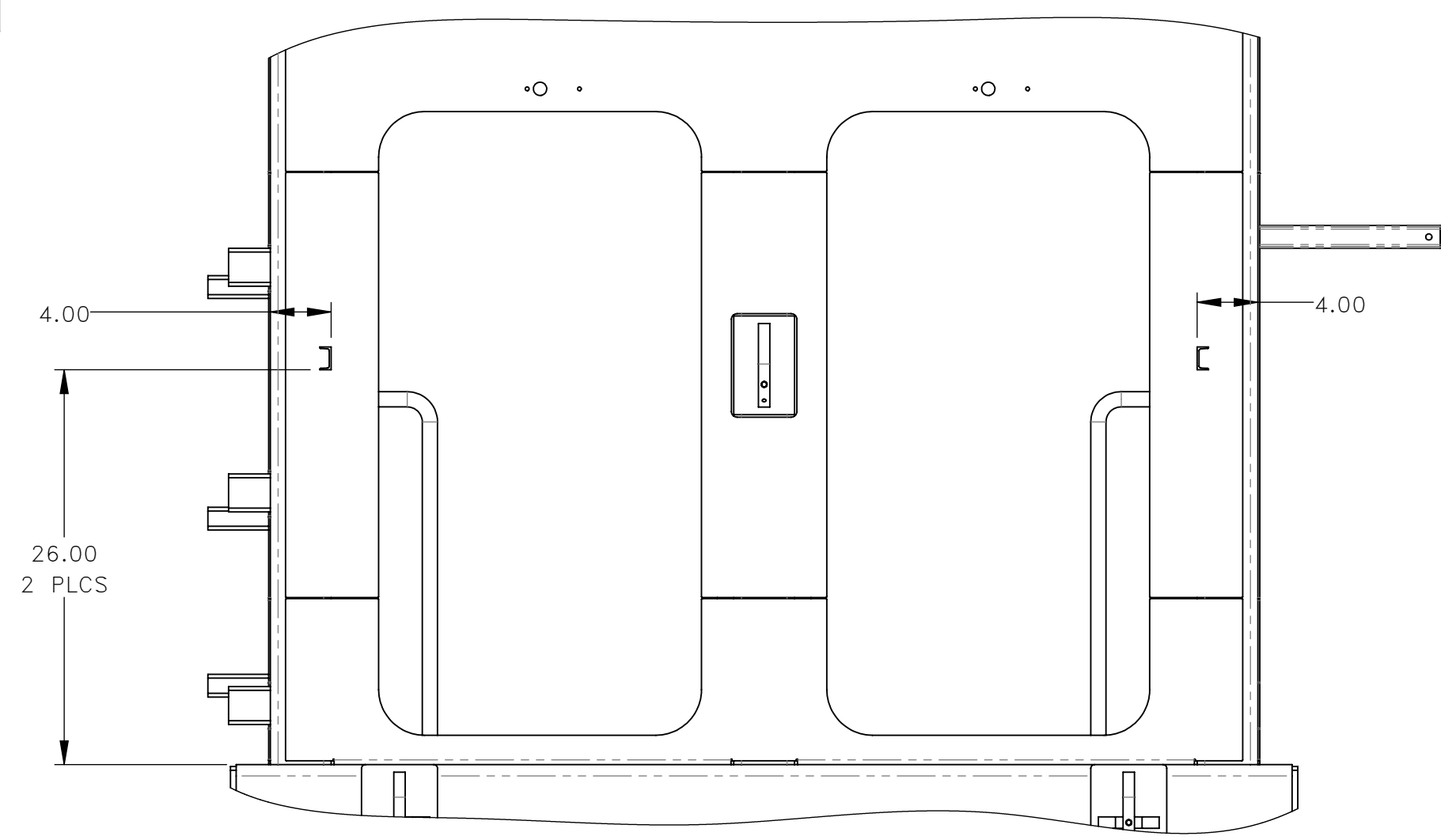

WELD CHANNELS 318861 AS ILLUSTRATED  
 NOTE HOLE LOCATION.  
 DISCARD THE TELESOPING BRACKETS THAT  
 ARE INCLUDED WITH MIRRORS, FASTEN MIRRORS  
 TO CHANNELS

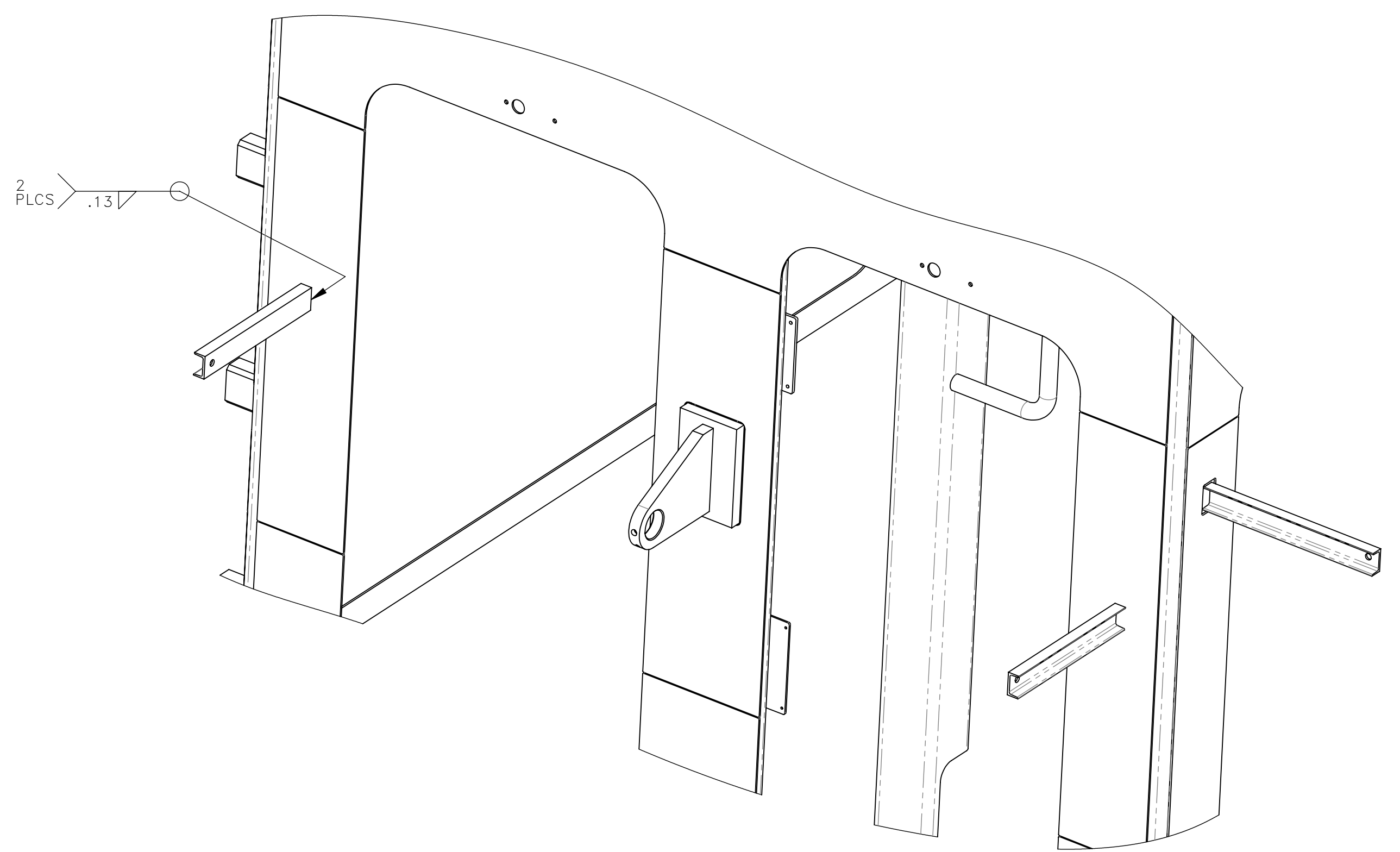

REV	EN	DESCRIPTION	DATE	DRN
1	3185	NEW RELEASE	5-18	MAE
DIMENSION TOLERANCES UNLESS OTHERWISE SPECIFIED				
LINEAR	.XX=±.03	.XXX=±.010		
ANGULAR	X°=±1°	X.X°=±.5°		
SURFACE FINISH NOT TO EXCEED	125 ✓	SMOOTH ALL SHARP EDGES CLEAN ALL WELDS		
THIS PRINT AND ALL INFORMATION WITHIN BELONGS TO RACINE RAILROAD PRODUCTS				
<b>RACINE RAILROAD PRODUCTS</b>				
RACINE, WISCONSIN USA				
DESCRIPTION				
INSTRUCTIONS, MIRROR KIT				
MATERIAL				
SEE BOM				
USED ON	793026	SCALE	DATE	
		1:10	05-25-18	
DRN	CHK	APP	JOB NO	SHEET
ME			RD150002	2 OF 2
EXP NO			DWG NO	
				800286