

NO.	QTY	DESCRIPTION	PART NO.
1	REF	MOUNT, LEFT FRONT ROLLER	781708
2	REF	MOUNT, LEFT REAR ROLLER	781709
3	REF	MOUNT, RIGHT REAR ROLLER	781711
4	REF	MOUNT, RIGHT FRONT ROLLER	781710

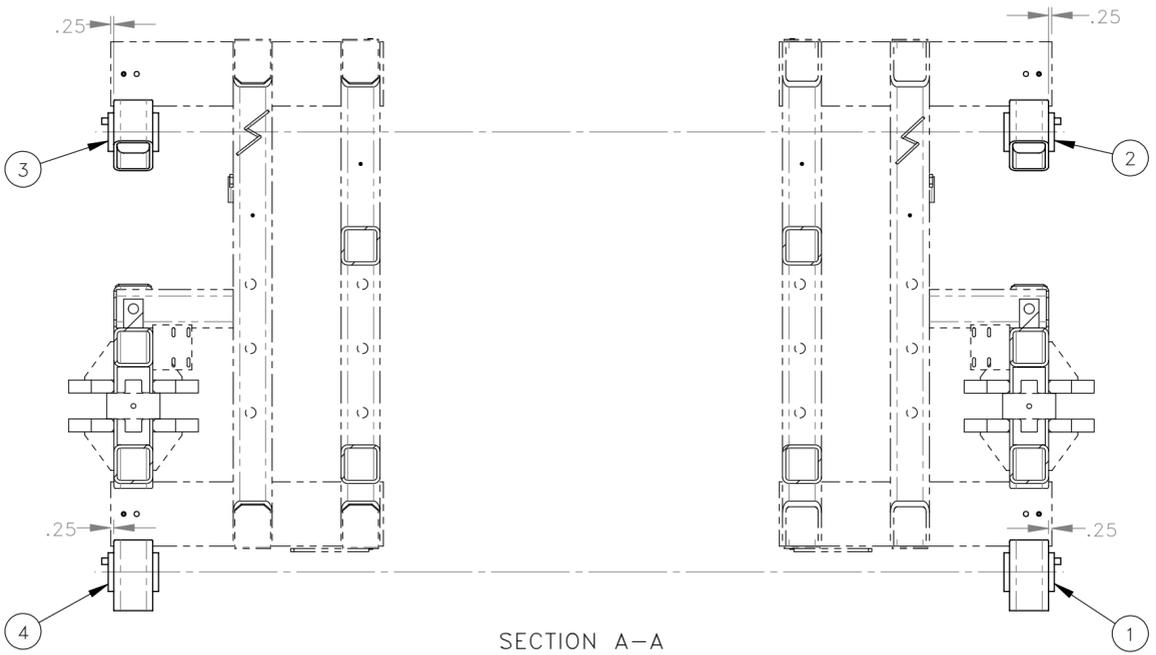

SECTION A-A

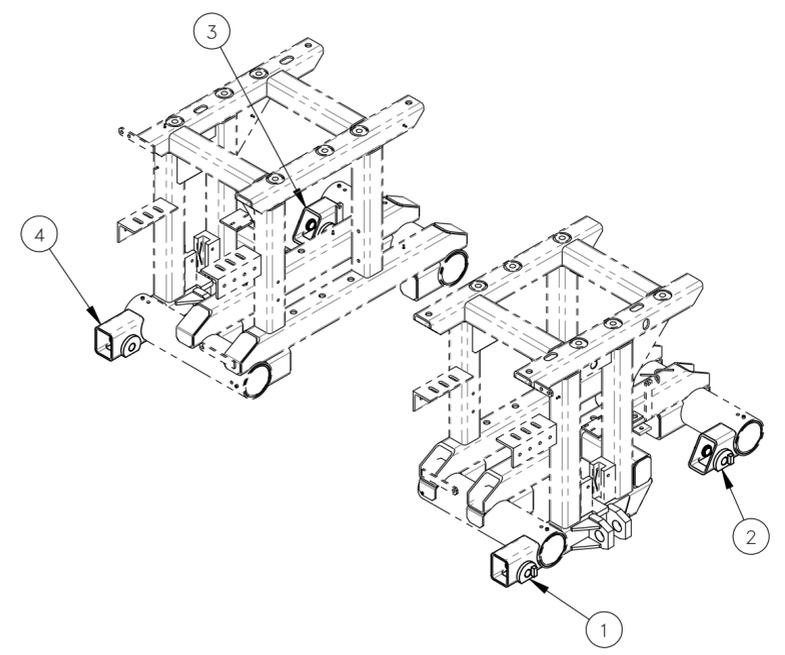

INSTRUCTIONS:
 1 REMOVE EXISTING ROLLERS, CUT OFF EXISTING ROLLER MOUNTS AND GRIND AREA SMOOTH.
 2 POSITION AND TACK EACH SUPPLIED ROLLER MOUNTS AS SHOWN.
 PLACE HOLE SIDE DOWN, PLACE ARC OF ROLLER MOUNT ONTO TUBE (FLUSH WITH FRAME TUBE, .25 INCH FROM TUBE END) AND WELD INTO PLACE.
 3 PRIME AND PAINT AREA, INSTALL ROLLERS.

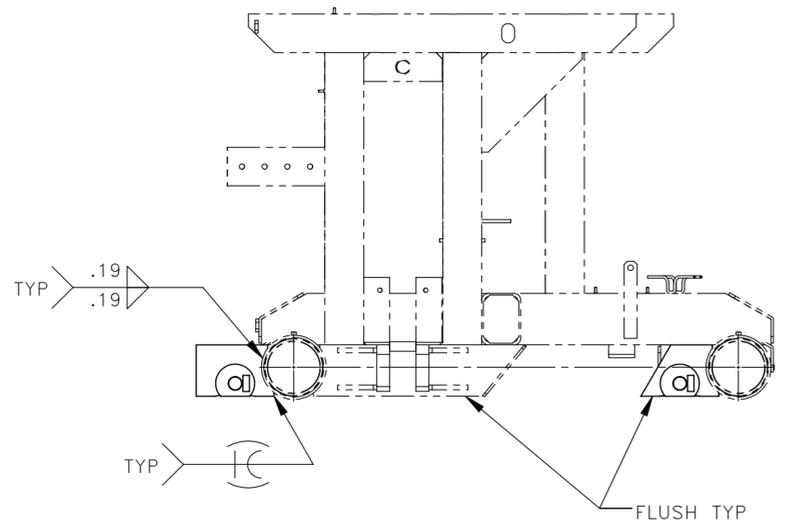
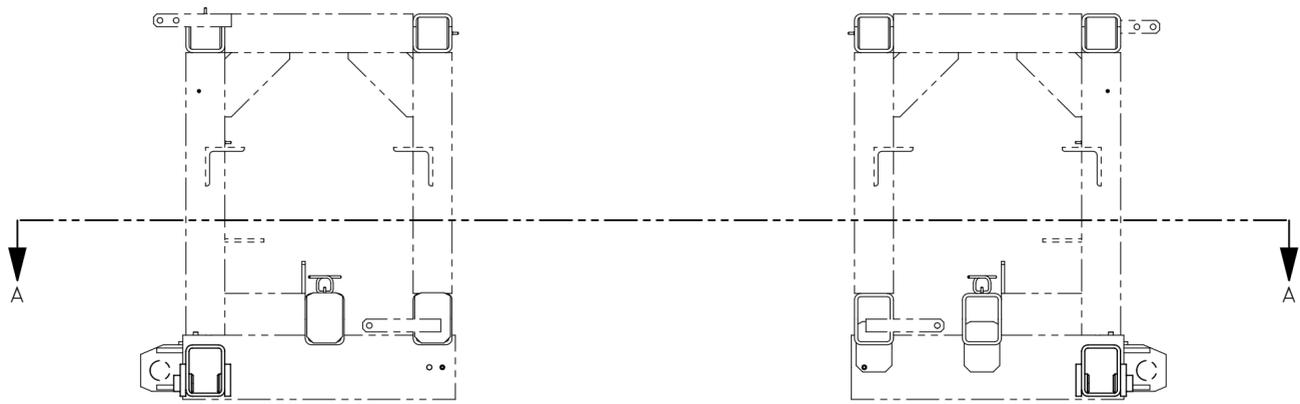

REV	EN	DESCRIPTION	DATE	DRN
1	4090	NEW RELEASE	4-19	MSO

DIMENSION TOLERANCES UNLESS OTHERWISE SPECIFIED

LINEAR	.XX=±.03	.XXX=±.010
ANGULAR	X°=±1°	X.X°=±.5°

SURFACE FINISH 125 ✓ SMOOTH ALL SHARP EDGES
 NOT TO EXCEED ✓ CLEAN ALL WELDS

THIS PRINT AND ALL INFORMATION WITHIN BELONGS TO RACINE RAILROAD PRODUCTS

RACINE RAILROAD PRODUCTS
 RACINE, WISCONSIN USA

DESCRIPTION
 INSTRUCTIONS, MECHANISM FRAME

MATERIAL
 SEE BOM

USED ON	793055	SCALE	1:10	DATE	04-18-19
DRN	MSO	CHK	APP	JOB NO	RD150003
DWG SIZE	C	CATALOG	K	DWG NO	800317