

NO.	QTY	DESCRIPTION	PART NO.
1	REF	POWER UNIT, GAS HYDRAULIC	719488
2	REF	KIT, HPU WHEEL	793072

DWG NO 800329

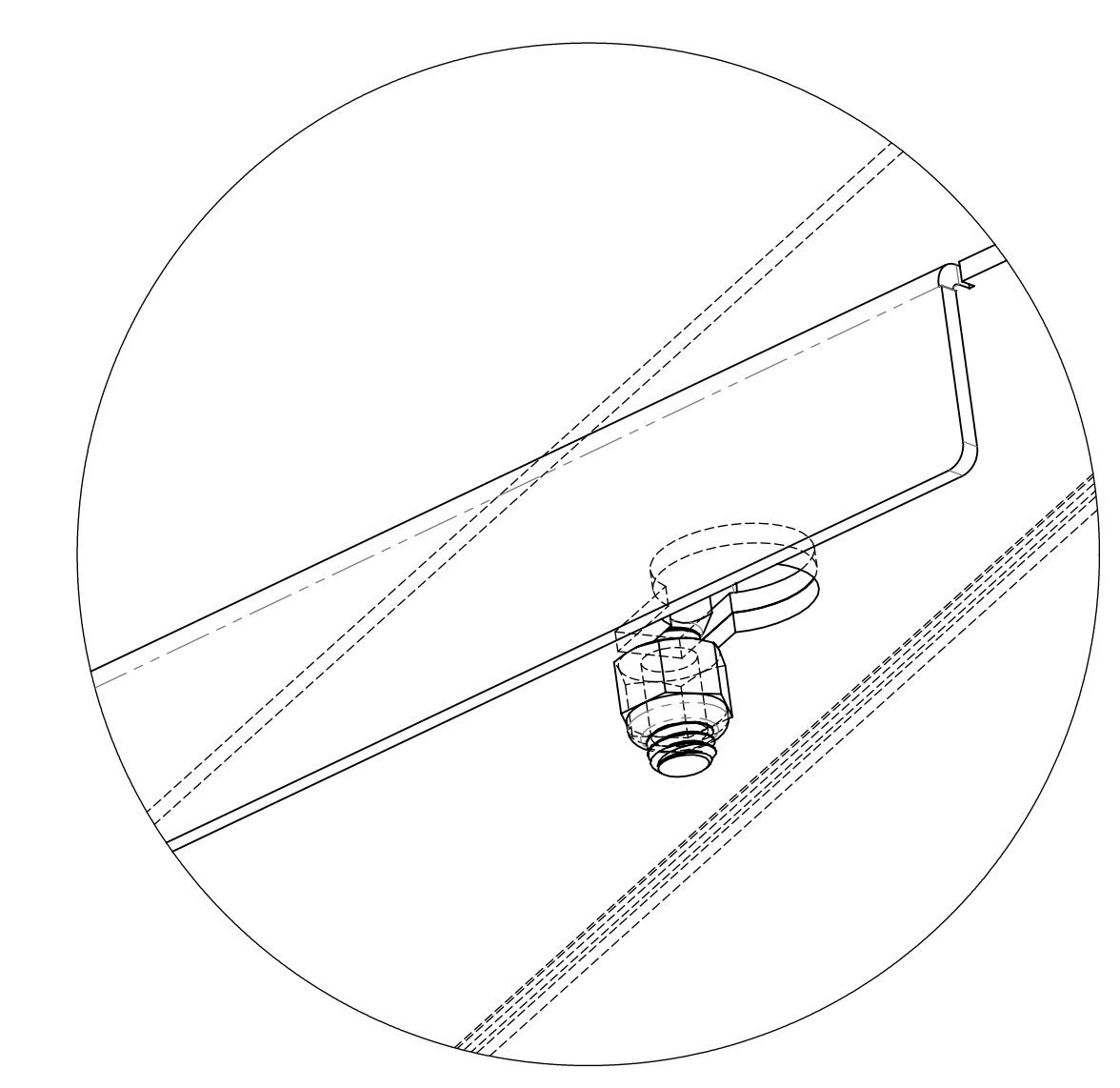
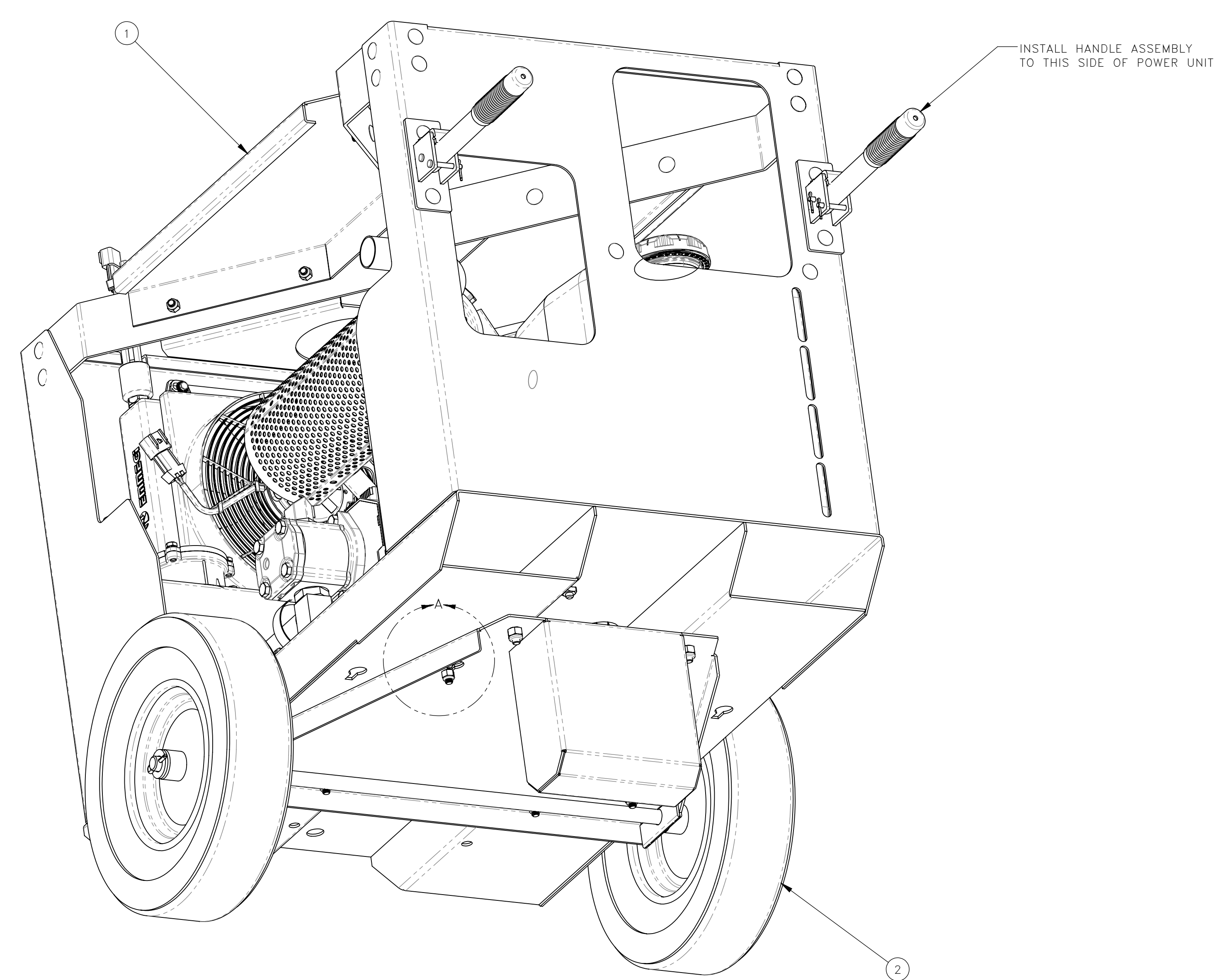

DETAIL A  
SCALE 1 : 1

REV	EN	DESCRIPTION	DATE	DRN
1	4815	NEW RELEASE	3-20	MAE

DIMENSION TOLERANCES UNLESS OTHERWISE SPECIFIED

LINEAR	.XX=±.03	.XXX=±.010
ANGULAR	X'=±1°	X.X'=±.5°

SURFACE FINISH 125/√ SMOOTH ALL SHARP EDGES  
NOT TO EXCEED CLEAN ALL WELDS

THIS PRINT AND ALL INFORMATION WITHIN  
BELONGS TO RACINE RAILROAD PRODUCTS

**RACINE RAILROAD PRODUCTS**  
RACINE, WISCONSIN USA

DESCRIPTION  
INSTRUCTIONS, HPU WHEEL KIT

MATERIAL  
SEE BOM

USED ON	SCALE	DATE
793072	1:4	XX-XX-XX

DRN	CHK	APP	JOB NO	SHEET
XXX			RD190003	1 OF 1

DWG SIZE	CATALOG	DWG NO
D	A	800329