

NO.	QTY	DESCRIPTION	PART NO.
1	REF	BELT, SERPENTINE	476036
2	REF	SUPPORT: IDLER PULLEY	476097
3	REF	SCR, HEX FLG: M8-1.25 X 25	476109
4	REF	PULLEY, IDLER: V-RIBBED	476110

THESE INSTRUCTIONS ARE FOR KIT 793126.

**REMOVAL:**

1. POWER OFF MACHINE AND TAG OUT BEFORE PERFORMING CONVERSION.
2. LOOSEN TENSIONER TO REMOVE SERPENTINE BELT.
3. DISCONNECT A/C COMPRESSOR & REMOVE KEEP FASTENERS & BELT WITH COMPRESSOR(SEE REMOVAL ISO VIEW).

**INSTALLATION:**

1. INSTALL IDLER PULLEY SUPPORT AS SHOWN (SEE REPLACEMENT ISO VIEW).
2. ATTACH THE IDLER PULLEY.
3. INSTALL NEW SERPENTINE BELT (SEE FRONT VIEW FOR PATTERN).
4. TENSION BELT WITH TENSIONER.

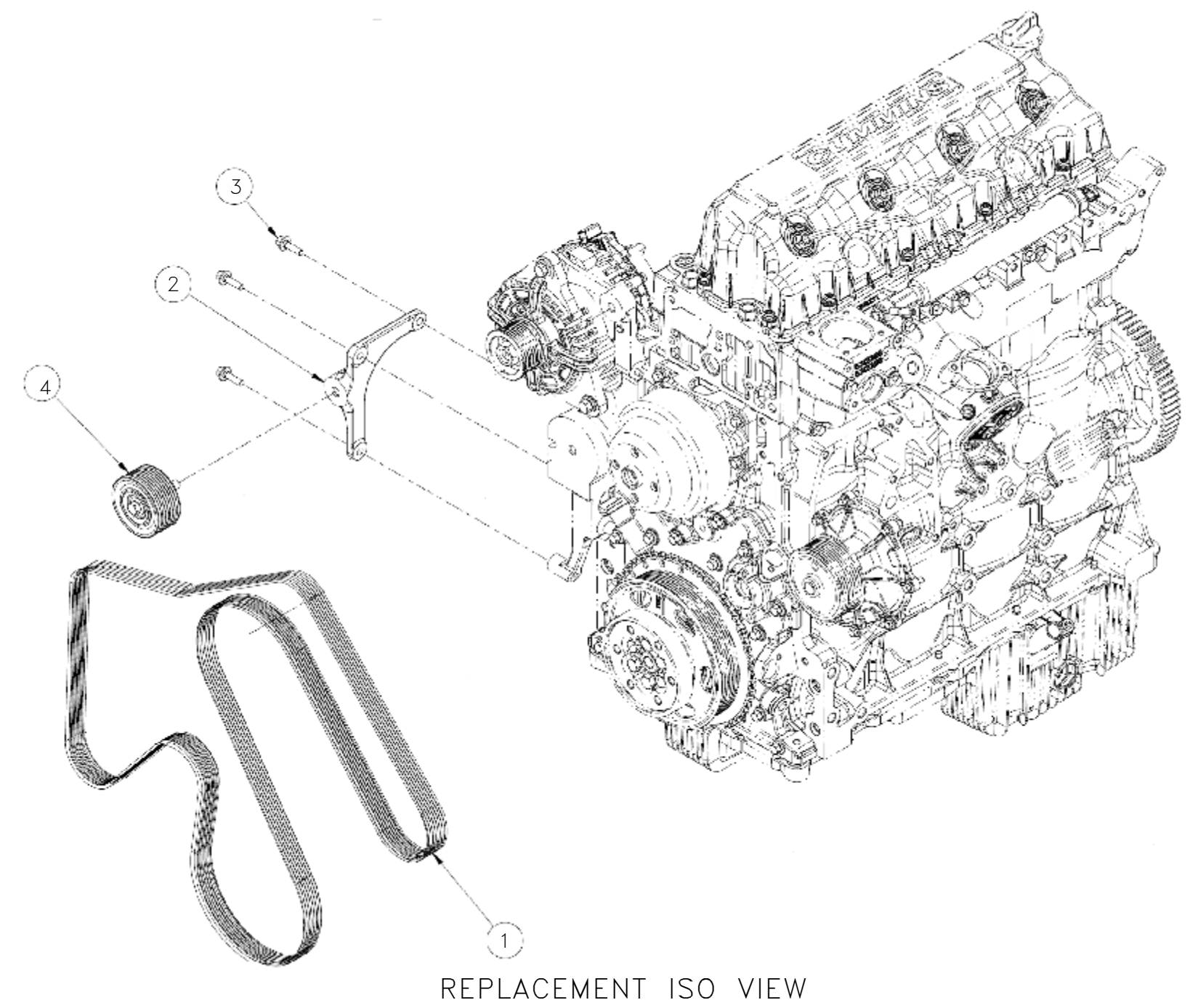
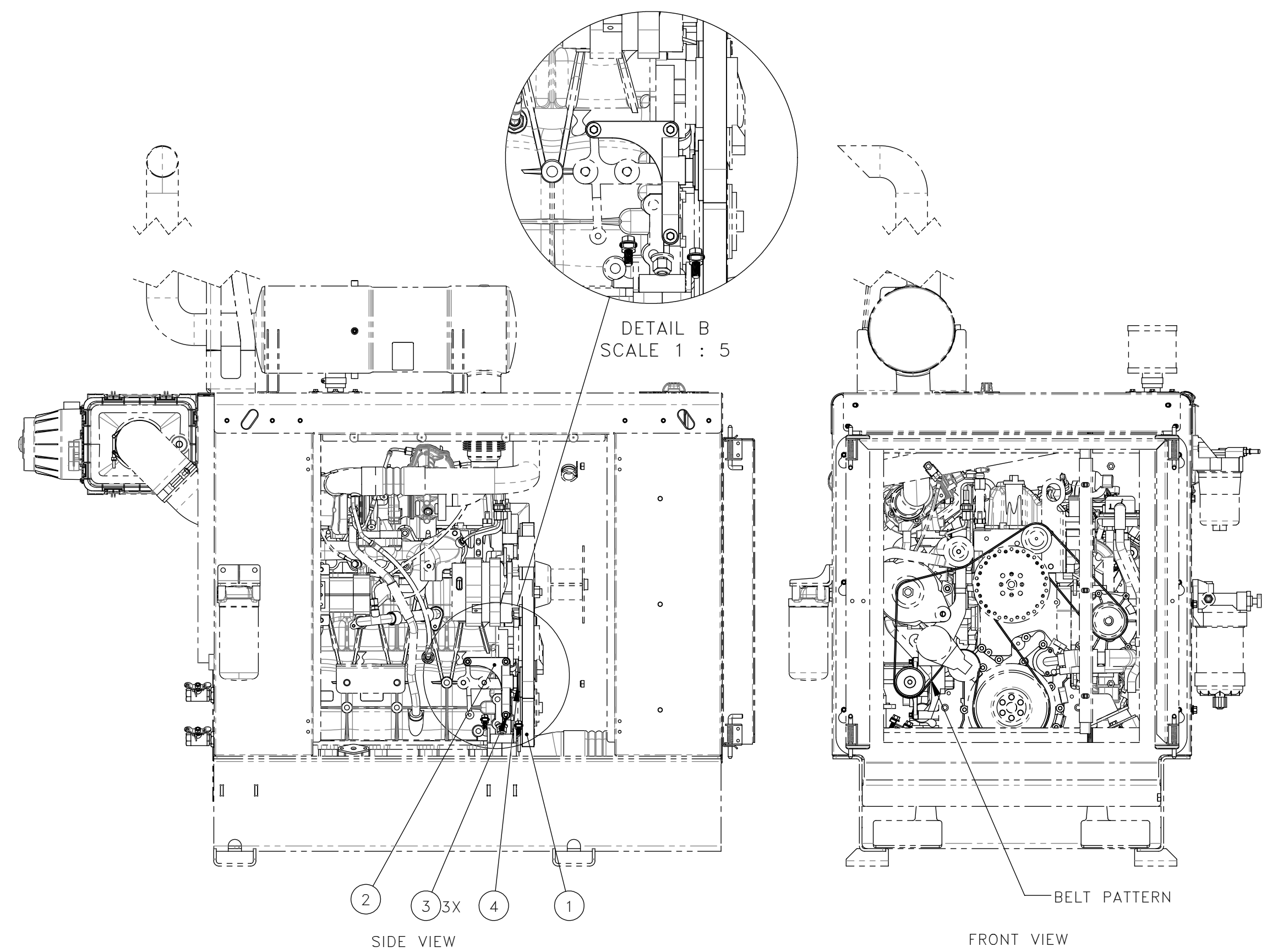

REV	EN	DESCRIPTION	DATE	DRN
1	5939	NEW RELEASE	10-21	PR

DIMENSION TOLERANCES UNLESS OTHERWISE SPECIFIED			
LINEAR	.XX=±.03	.XXX=±.010	
ANGULAR	X°=±1°	X.X°=±.5°	
SURFACE FINISH NOT TO EXCEED	125 ✓	SMOOTH ALL SHARP EDGES CLEAN ALL WELDS	

THIS PRINT AND ALL INFORMATION WITHIN BELONGS TO RACINE RAILROAD PRODUCTS

**RACINE RAILROAD PRODUCTS**  
RACINE, WISCONSIN USA

DESCRIPTION				
INSTRUCTIONS, CUMMINS 3.8 A/C COMP. ALTERATION KIT				
MATERIAL				
SEE BOM				
USED ON	793126	SCALE	DATE	
		1:10	10-04-21	
DRN	CHK	APP	JOB NO	SHEET
PR			RD150003	1 OF 1
DWG SIZE	CATALOG	DWG NO		
C	A	800363		