

QTY	NO.	DESCRIPTION	PART NO.
REF	1	ELBOW, 90°: #20 JIC(M) X #20 SAE(M)	463396
REF	2	ADAPTER, #20 JIC(F) X #20 SAE(M)	463549
REF	3	SUPPRESSOR, HYDRAULIC	472292
REF	4	DECAL, NITROGEN PRECHARGE 0 PSI	477018

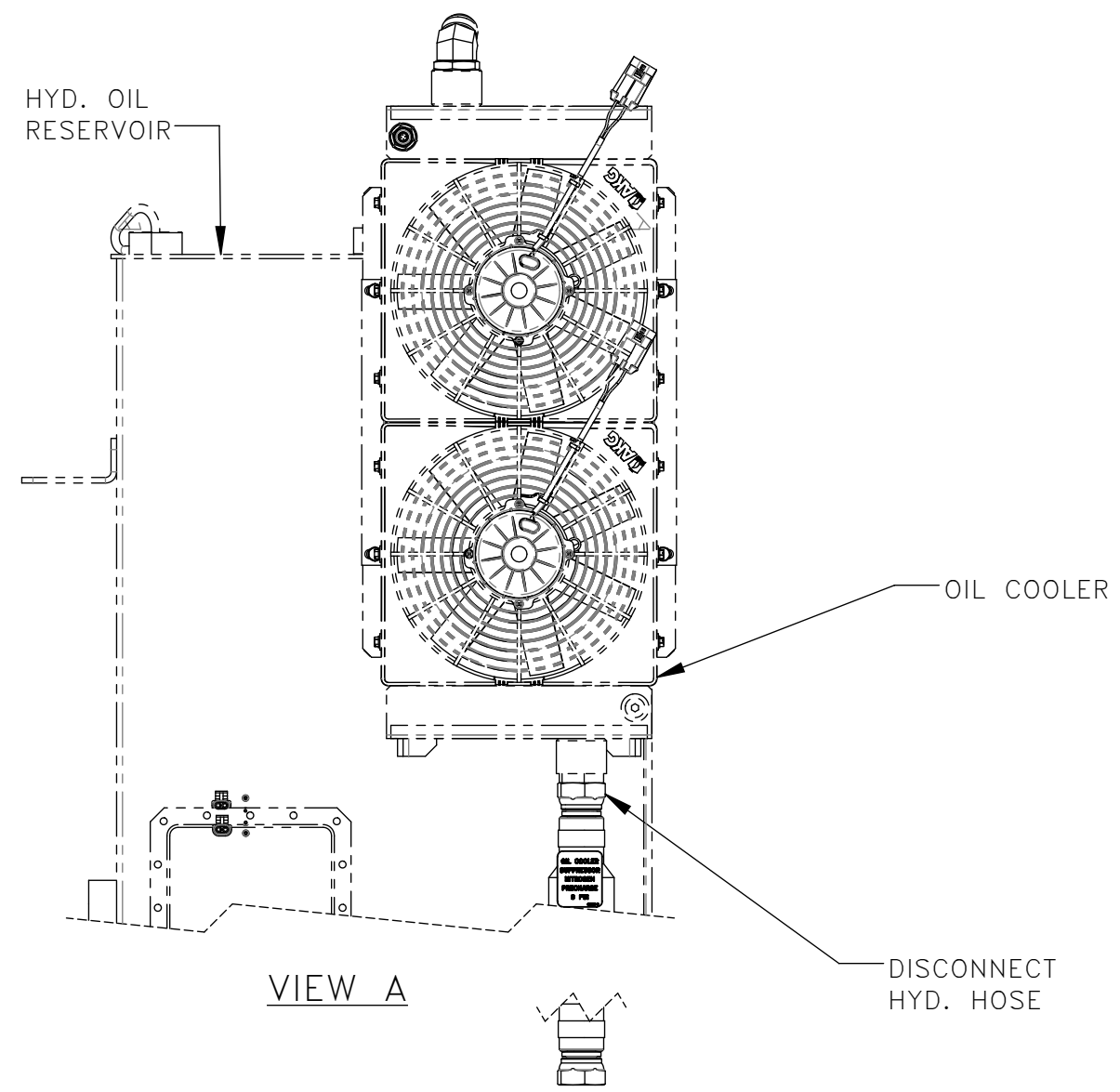

THESE INSTRUCTIONS ARE FOR KIT 793133

REMOVAL:

1. POWER OFF MACHINE AND TAG OUT BEFORE PERFORMING CONVERSION
2. DISCONNECT HYD. HOSE FROM THE BOTTOM OF OIL COOLER (SEE VIEW A).

INSTALLATION:

1. ADD ADAPTER, SUPPRESSOR AND ELBOW AS SHOWN (SEE ISO VIEW B).
2. REATTACH HYD. HOSE TO ELBOW (SEE VIEW C).
3. ADD DECAL TO THE SUPPRESSOR, PLACE TO BE SEEN. (SEE ISO VIEW B).

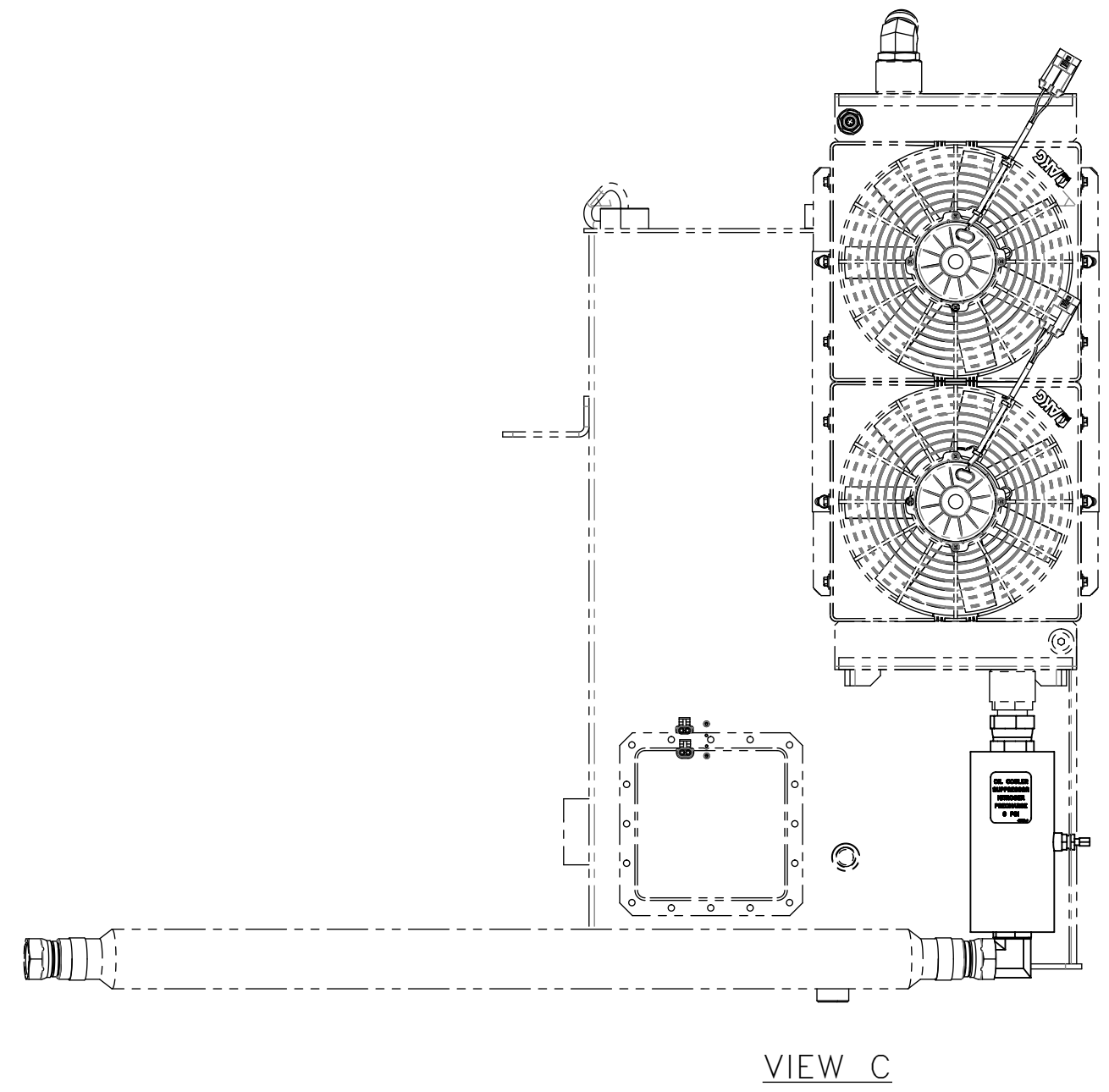
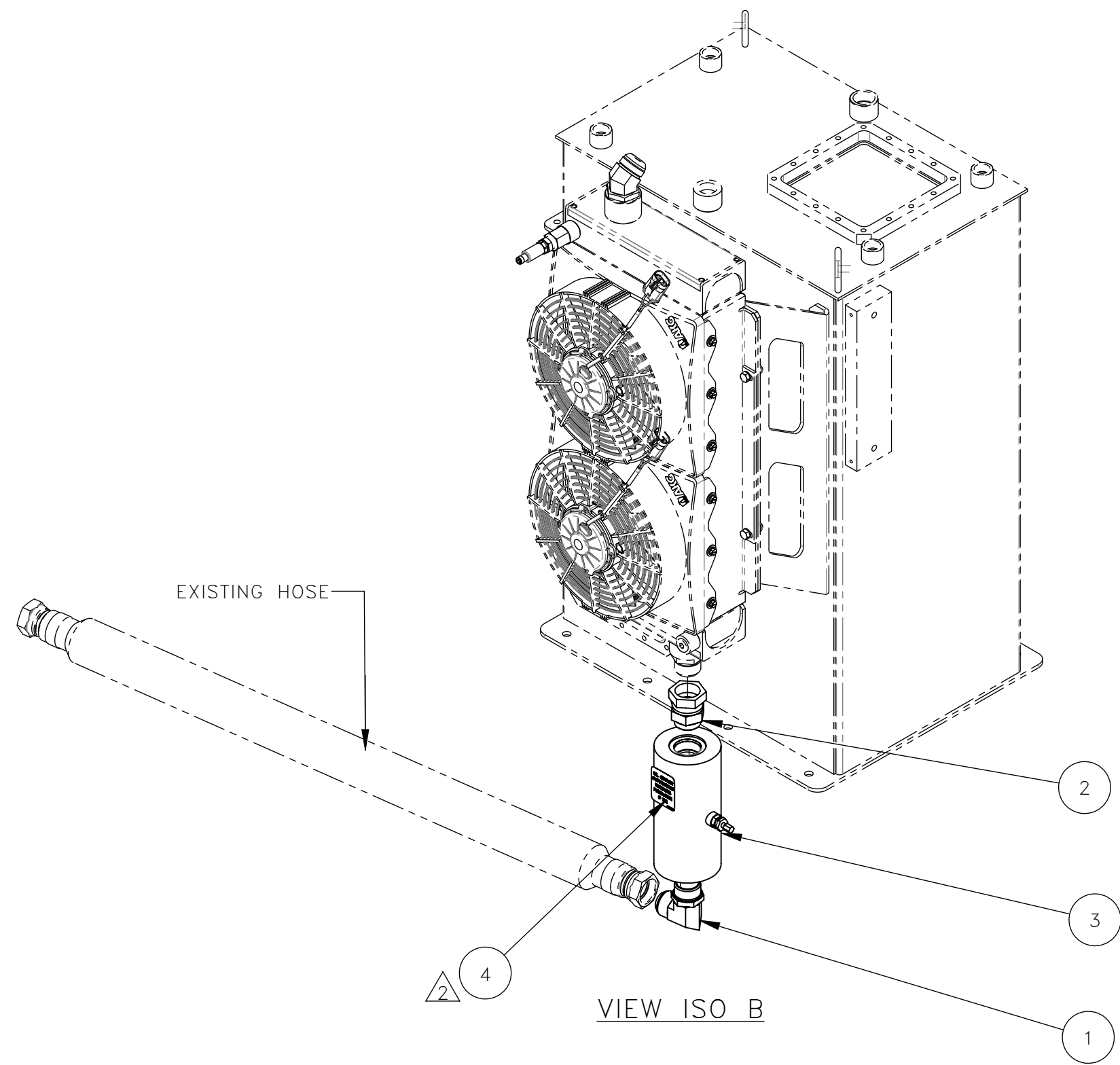

REV	EN	DESCRIPTION	DATE	DRN
1	6044	NEW RELEASE	1-22	PR
2	00096	SEE EN FOR DETAILS	4-23	PR

DIMENSION TOLERANCES UNLESS OTHERWISE SPECIFIED

LINEAR	.XX=±.03	.XXX=±.010
ANGULAR	X°=±1°	X.X°=±.5°

SURFACE FINISH 125/ ✓ SMOOTH ALL SHARP EDGES
NOT TO EXCEED CLEAN ALL WELDS

THIS PRINT AND ALL INFORMATION WITHIN BELONGS TO RACINE RAILROAD PRODUCTS

RACINE RAILROAD PRODUCTS
RACINE, WISCONSIN USA

DESCRIPTION
INSTRUCTIONS, ATPI OIL COOLER SUPPRESSOR KIT

MATERIAL SEE BOM

USED ON 793133 SCALE 1:8 DATE 12-21-21

DRN PR CHK APP JOB NO RD150003 SHEET 1 OF 1

DWG SIZE C CATALOG A DWG NO 800379