

THESE INSTRUCTIONS ARE FOR KIT CMA200 MASTER CONTROL VALVES

TOOLS AND SUPPLIES REQUIRED:

- 4 MM ALLEN WRENCH OR HEX SOCKET
- TORQUE WRENCH (SIZED FOR APPROXIMATELY 80 IN-LB. [9 NM])
- PV/CV GUIDE PINS: SEE CMA VALVE DRAWING FOR SERVICE PARTS RRP#473763
*(GUIDE PINS ARE REUSABLE UNLESS DAMAGED)

- 13/16 IN (20.5 MM) HEX SOCKET
- TORQUE WRENCH (SIZED FOR APPROXIMATELY 995 IN-LB. [110-115 NM])
- 3/4 IN (19.0 MM) HEX SOCKET
- TORQUE WRENCH (SIZED FOR APPROXIMATELY 550 IN-LB. [60-65 NM])
- SEALS: SEE BOM FOR CMA VALVE PART NUMBERS KITS

CMA VALVES MACHINE REMOVAL:

**SEE MACHINE DRAWINGS FOR BOTH CMA VALVE LOCATIONS.

1. POWER OFF THE MACHINE AND TAG OUT BEFORE PERFORMING CONVERSION.
2. ENSURE THAT THE PRIME MOVER AND HYDRAULIC PUMP ARE BOTH OFF.
3. LABEL EACH OF THE ELECTRICAL CABLES AND HYDRAULIC HOSES FOR CORRECT RE-ASSEMBLY.
4. REMOVE VALVES FROM THE MACHINE AND KEEP EXISTING FASTENERS.
5. MARK CMA VALVES LEFT OR RIGHT FOR CORRECT ORIENTATION TO BE MAINTAINED.

PV AND CV SEAL REPLACEMENT PROCEDURE:

** PLACE CMA VALVES ON A FLAT SURFACE SHOWN IN ISO VIEWS.

6. START WITH CONDITIONING VALVE DISCONNECT ONE CABLE ON FROM THE NEXT PROCEED DOWN THE LINE OF PILOT VALVES (SEE FIG 1.0 & ISO VIEW II).
7. REMOVE TWO BOLTS FROM DIAGONAL CORNERS USING A 4 MM HEX ALLEN.
8. INSERT TWO GUIDE RODS (TOOL LIST ABOVE) INTO THE OPEN HOLES AND THREAD UNTIL SNUG (THIS PREVENTS DAMAGE TO LVDT CORE MAGNETIC STRIPS).
9. DE-TORQUE BOTH OF THE OTHER BOLTS AND THEN CAREFULLY LOOSEN EACH BOLT, IN-TURN EQUALLY.
10. THEN REMOVE THE REMAINING TWO BOLTS (THERE MAY BE SPRINGS COMPRESSED KEEP WITH FASTENERS).
11. LIFT THE PILOT VALVE OR CONDITIONING VALVE STRAIGHT UP & OFF THE FACE OF THE VALVE BANK. CARE SHOULD BE TAKEN AS TO PREVENT DAMAGE TO THE SENSOR BODIES OVER THE LVDT CORES.

12. REMOVE AND DISCARD O-RINGS AND CLEAN THE AREA OF ANY DEBRIS. (SEE FIG 2.1).
13. INSTALL CV AND PV SEALS INTO THE MAIN VALVE FACE ENSURING THAT THEY REMAIN IN POSITION (SEE FIG 2.2).
14. CAREFULLY INSTALL THE PILOT VALVE ENSURING THAT THE O-RINGS REMAIN IN-PLACE AND THAT THE VALVE IS LOWERED SUCH THAT THE POSITION SENSORS PASS OVER THE LVDT CORES IN THE SPOOLS WITHOUT MAKING CONTACT. THE VALVE SHOULD BE INSTALLED SUCH THAT THE CABLE ASSEMBLIES CAN ALL BE CONNECTED ON THE SAME SIDE FOR RECONNECTING WHEN COMPLETELY FINISHED (SEE ISO VIEWS).
15. PLACE TWO BOLTS INTO DIAGONAL FREE HOLES AND TAKE TURNS THREADING BOTH BOLTS SO THAT THEY PULL DOWN THE PILOT VALVE LEVEL. SNUG BOLTS UNTIL O-RINGS ARE COMPRESSED. SNUG FOLLOWING A CRISSCROSS PATTERN, TORQUE EACH BOLT TO $9 \pm .5$ NM [80 ± 5 IN-LB.].
16. REMOVE TWO GUIDE PINS, INSTALL TWO REMAINING BOLTS AND SNUG UNTIL O-RINGS ARE COMPRESSED.
17. INSTALL TWO REMAINING BOLTS, TAKE TURNS THREADING BOTH BOLTS, FOLLOWING A CRISSCROSS PATTERN, TORQUE EACH BOLT TO $9 \pm .5$ NM [80 ± 5 IN-LB.].

RELIEF PLUG REPLACEMENT PROCEDURE:

** PLACE CMA VALVES WITH RELIEF PORTS (SEE SIDE VIEW).

18. REMOVE AUX PORT RELIEF PLUGS USING 20.5 MM (13/16") HEX SOCKET.
 20. REMOVE FROM CAVITY THEN DISCARD O-RING ON AUX PORT RELIEF PLUG.
 21. ADD NEW O-RING MAKING SURE IT IS SEATED PROPERLY AND THREAD INTO THE CAVITY.
 23. TORQUE PLUG TO 995 IN-LB. [110-115 NM] USING 20.5 MM (13/16") HEX SOCKET.
- ** AUX RELIEF PORT PLUGS ON BOTH ENDS OF THE WORK SECTIONS AND ONE ON THE CONDITIONING VALVE.

WORK SECTIONS SEAL REPLACEMENT PROCEDURE:

** PLACE CMA VALVES WITH PV AND CV VALVES UPWARD POSITION (SEE SIDE VIEW).

24. REMOVE TIE ROD NUTS USING A 19 MM (3/4") HEX SOCKET.
25. REMOVE THE END COVER ASSEMBLY.
26. LABEL & REMOVE WORK SECTIONS ENSURING THAT THE ORDER OF THE WORK SECTIONS IS PRESERVED. IT IS IMPORTANT THAT THE ORDER REMAIN CONSISTENT.
27. REPLACE O-RINGS AND ENSURE ALL O-RINGS ARE INSTALLED ON THAT WORK SECTION AND SEATED BEFORE PUSHING TOGETHER USING THE TIE RODS AS GUIDES.
28. FOR EACH SECTION DISCARD O-RINGS AND CLEAN SURFACE AREA OF DEBRIS. THEN STACK ALL WORK SECTIONS IN THEIR ORIGINAL ORDER ENSURING THAT THE O-RINGS STAY SEATED BEFORE PUSHING TOGETHER.
29. CAREFULLY INSTALL THE END COVER ENSURING THAT THE INTERFACE O-RINGS REMAIN IN PLACE. TORQUE WRENCH (SIZED FOR APPROXIMATELY 550 IN-LB. [60-65 NM]).
30. ASSEMBLE TIE ROD NUTS WITH A 19 MM (3/4") HEX SOCKET AND APPLY A TORQUE OF 550 IN-LB. [60-65 NM].
31. RECONNECT ALL CABLES ENSURE RETENTION TAB IS UP AND LOCKED ON EACH (SEE FIG 1.0).

CMA VALVES MACHINE ATTACHMENT:

32. USE EXISTING FASTENERS TO REMOUNT CMA VALVES IN THERE PROPER LOCATIONS.
33. CONNECT ALL THE ELECTRICAL CABLES AND HYDRAULIC HOSES PER THEIR LABELED PER DESIGNATIONS.
34. REMOVE TAGOUT AND POWER ON THE MACHINE.

**REQUEST AIR-BLEED FOR ALL OF THE WORK SECTIONS AND THE INLETS.

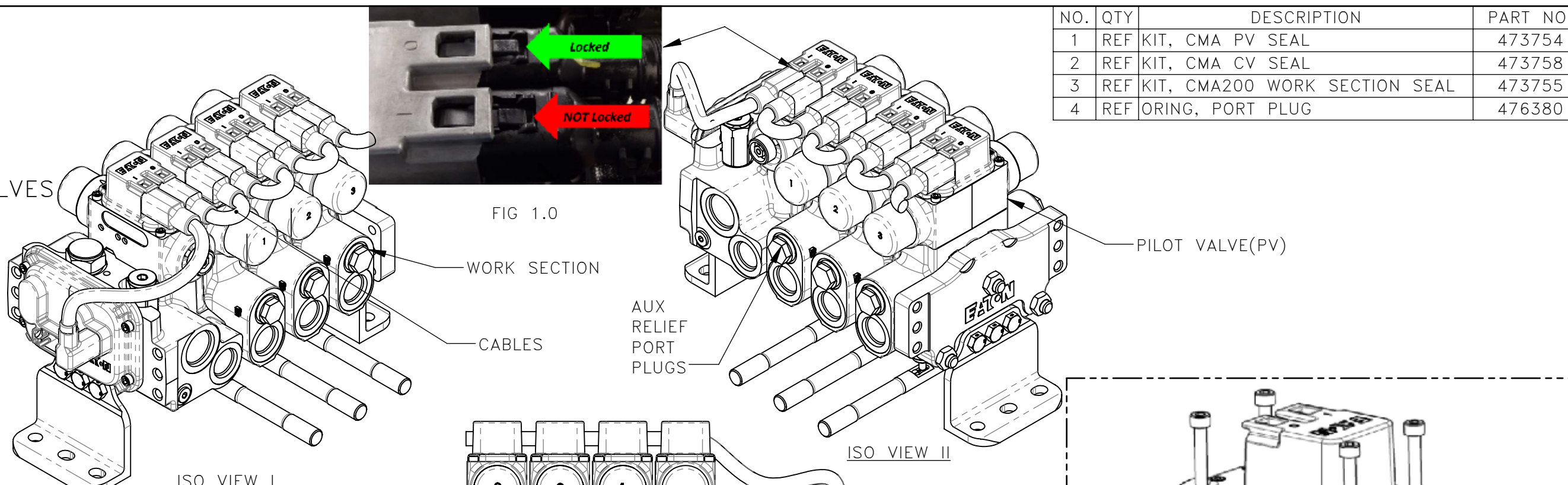

NO.	QTY	DESCRIPTION	PART NO.
1	REF	KIT, CMA PV SEAL	473754
2	REF	KIT, CMA CV SEAL	473758
3	REF	KIT, CMA200 WORK SECTION SEAL	473755
4	REF	ORING, PORT PLUG	476380

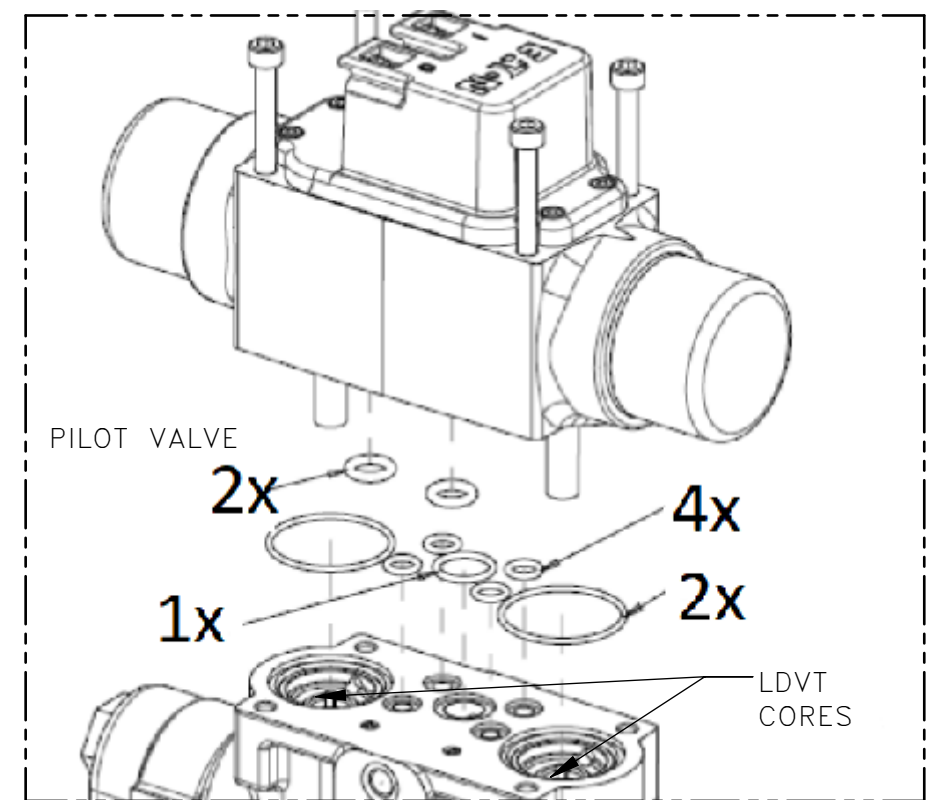
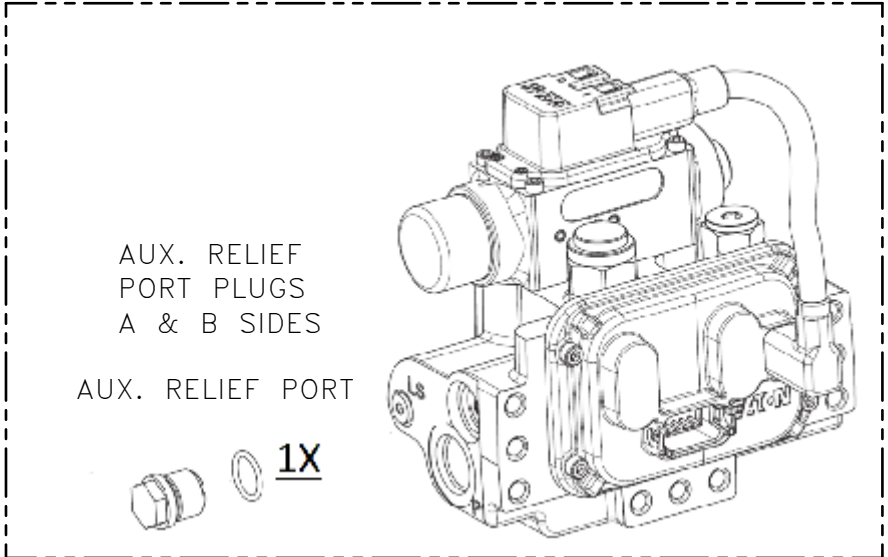
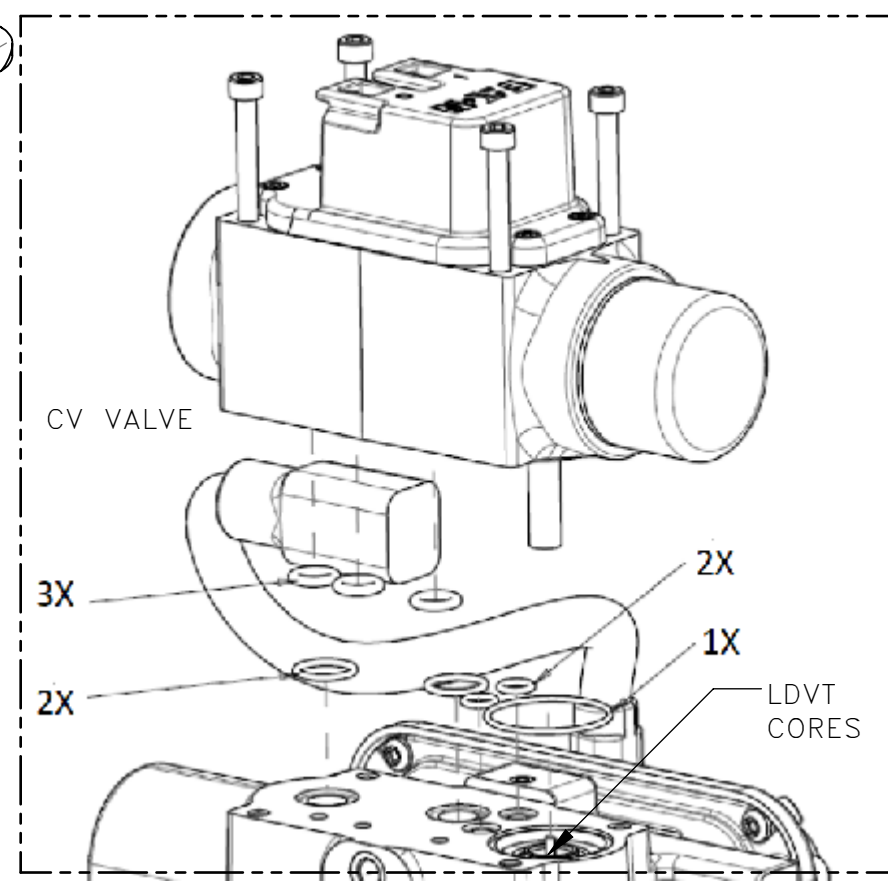
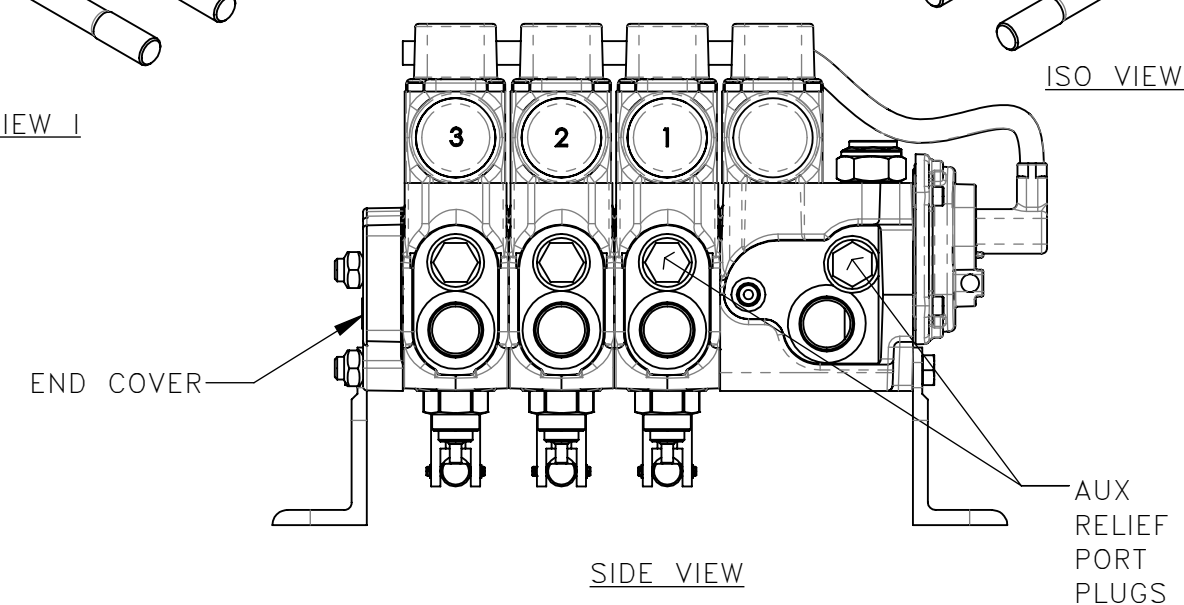

FIG 2.2 CMA200 PV SEALS
** PER WORK SECTION

FIG. 3.0 CMA200 WORK SECTION PORT PLUG O-RING
** 2 PER WORK SECTIONS & 1 PER CONDITIONING VALVE.

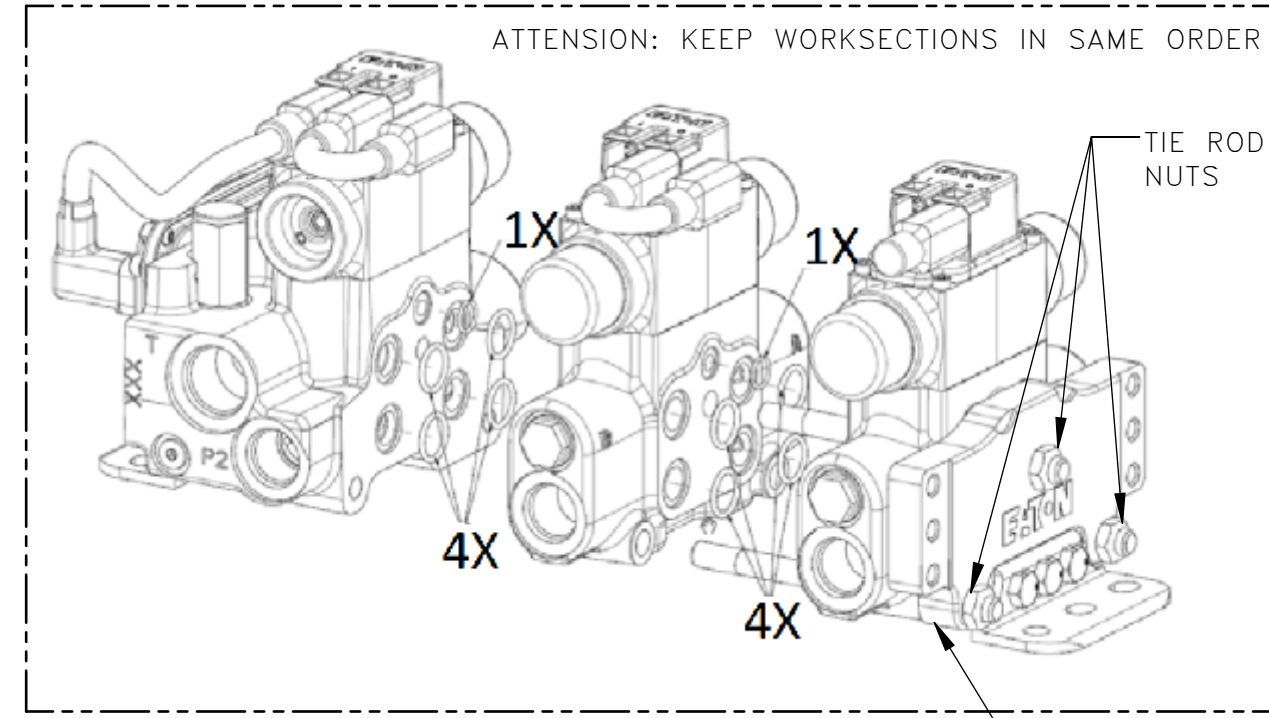

FIG. 4.0 CMA200 WORK SECTION SEALS
**WORK SECTION QUANTITIES MAY VARY WITH EACH KIT.

REV	EN	DESCRIPTION	DATE	DRN
1	6203	NEW RELEASE	4-22	PR

DIMENSION TOLERANCES UNLESS OTHERWISE SPECIFIED

LINEAR	.XX=±.03	.XXX=±.010
ANGULAR	X°=±1°	X.X°=±.5°

SURFACE FINISH 125/ NOT TO EXCEED SMOOTH ALL SHARP EDGES CLEAN ALL WELDS

THIS PRINT AND ALL INFORMATION WITHIN BELONGS TO RACINE RAILROAD PRODUCTS

RACINE RAILROAD PRODUCTS
RACINE, WISCONSIN USA

DESCRIPTION
INSTRUCTIONS, CMA200 MASTER CONTROL VALVES

MATERIAL
SEE BOM

USED ON 793138 SCALE 1:4 DATE 04-18-22

DRN PR CHK APP JOB NO RD190005 SHEET 1 OF 1

DWG SIZE C CATALOG A DWG NO 800390