

THESE INSTRUCTIONS ARE FOR KIT 793189.

REMOVAL:

1. ENSURE MACHINE IS POWERED OFF AND LOCK OUT-TAG OUT IS IN PLACE BEFORE PERFORMING THE CONVERSION & ENGINE EXHAUST IS COOLED.
2. REMOVE UPPER EXHAUST STACK & KEEP CLAMP AND FASTENERS (SEE VIEW A).

INSTALLATION:

3. PLACE NEW UPPER STACK ITEM 1 IN THE SAME DIRECTION THE EXISTING PIPE WAS FACING AND CLAMP INTO PLACE (SEE ISO VIEW).
4. PLACE RAIN CAP ITEM 2 WITH FLAP OPENING UPWARD CLAMP SECURELY (SEE DETAIL B).

NO.	QTY	DESCRIPTION	PART NO.
1	REF	PIPE, EXHAUST: 3 IN	324124
2	REF	CAP, EXHAUST RAIN	477081

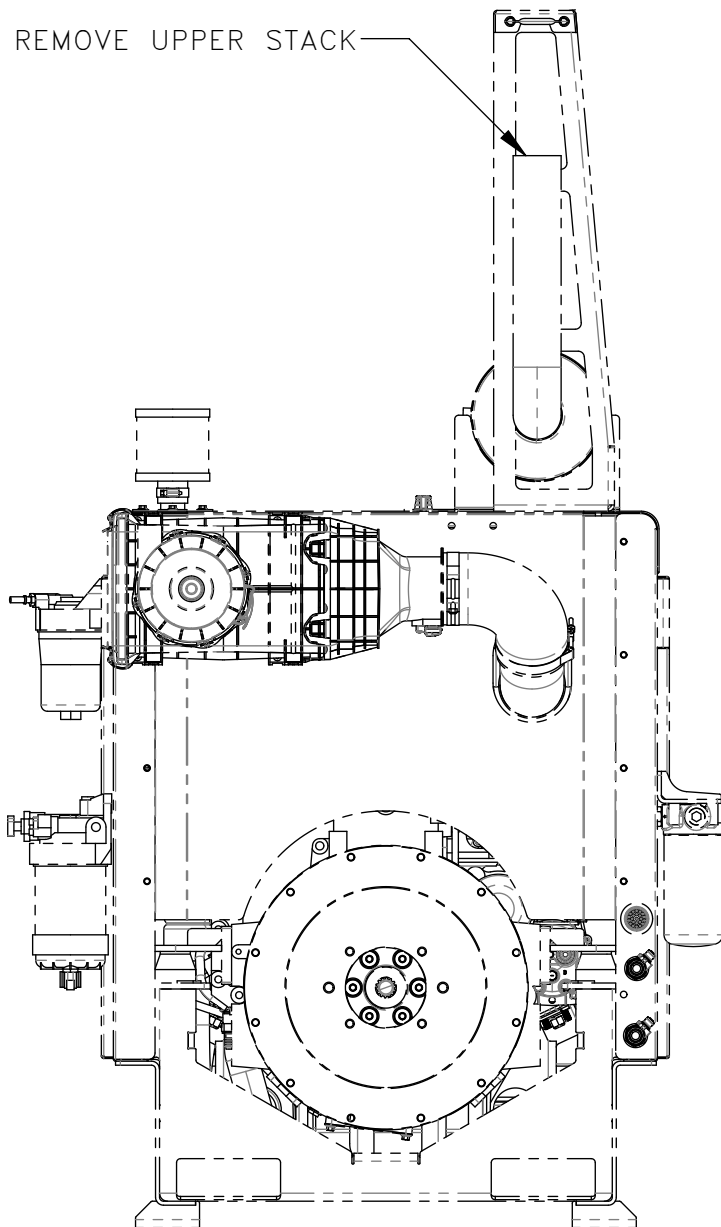

VIEW A

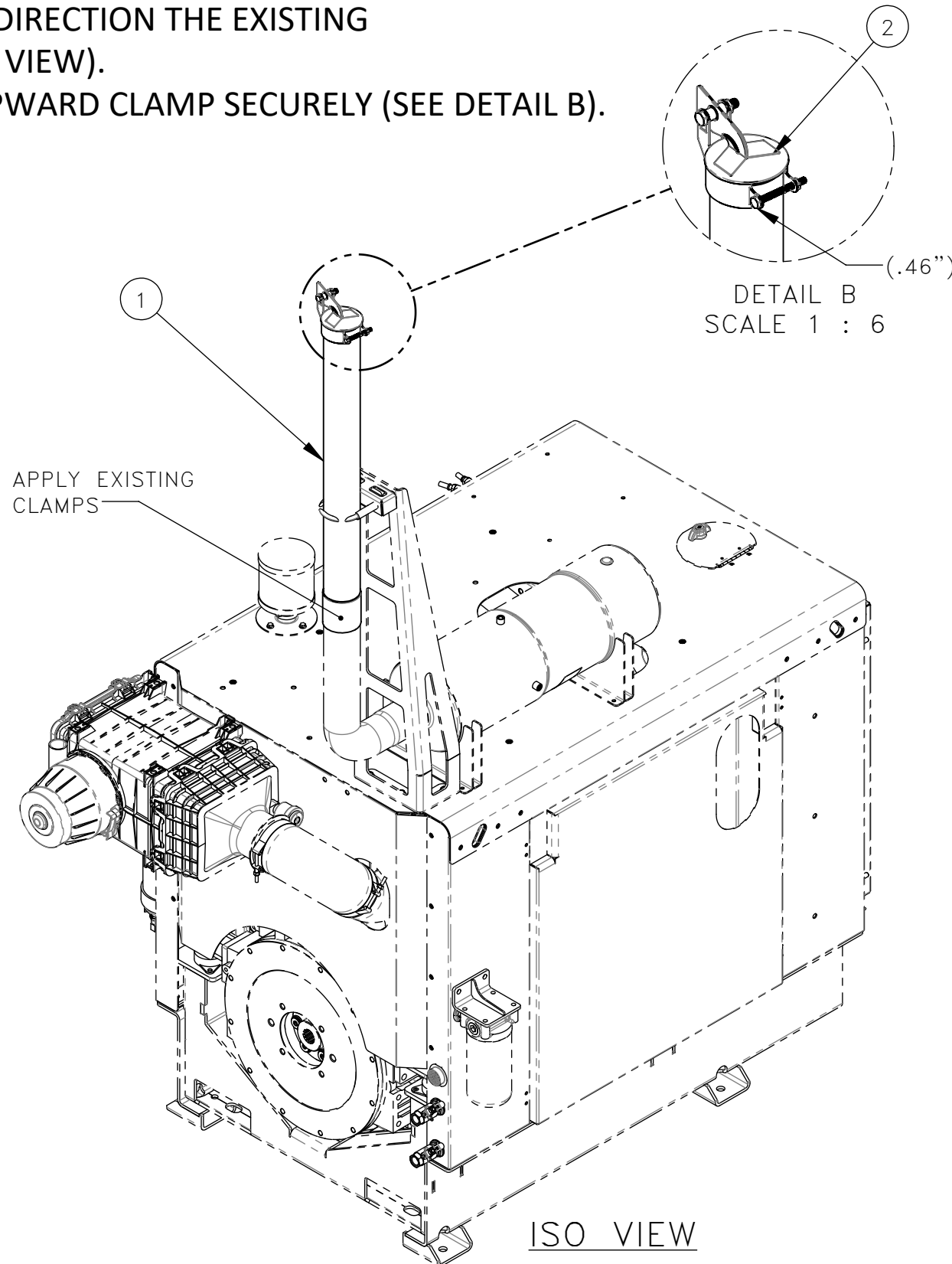

ISO VIEW

REV	EN	DESCRIPTION	DATE	DRN
1	00150	NEW RELEASE	6-23	PR
2	00177	UPDATE PICTORIALLY W/ STRAIGHT PIPE	6-23	PR

DIMENSION TOLERANCES UNLESS OTHERWISE SPECIFIED

LINEAR	.XX=±.03	.XXX=±.010	KERF ALLOW.
ANGULAR	X°=±1°	X.X°=±.5°	

SURFACE FINISH 125/ ✓ SMOOTH ALL SHARP EDGES
NOT TO EXCEED CLEAN ALL WELDS

THIS PRINT AND ALL INFORMATION WITHIN BELONGS TO RACINE RAILROAD PRODUCTS

RACINE RAILROAD PRODUCTS
RACINE, WISCONSIN USA

DESCRIPTION
INSTRUCTIONS, EXHAUST STACK
RAIN CAP KIT

MATERIAL TYPE REFERENCE

USED ON	793186	SCALE	1:12	DATE	06-08-23
DRN	PR	WEIGHT (LBS)	0.00	JOB NO	RD190005
				SHEET	1 OF 1
DWG SIZE	B	CATALOG	A	DWG NO	800411