

Service Bulletin

Maintenance of Way Equipment

Date: 06.15.2020

RRP Service Bulletin No: RRP SB353

Title: DASP Tooling Kit Update

Rating:



ALERT
 (Potential Problem)



INFORMATION
 (Action Is Optional)



DIRECTIVE
 (Action Is Required)



PRODUCT IMPROVEMENT
 (Enhance Product)

Product Series: Dual Anchor Spreader Plate (DASP), 914570, 930582, 935582, 945582, 955582

Serial No:

935582	DASP-270	CN-W	CN64084
935582	DASP-277	CN-W	CN64085
935582	DASP-284	CN-W	CN64094
935582	DASP-285	CN-W	CN64095
935582	DASP-286	CN-W	CN64096
935582	DASP-287	CN-W	CN64097

945582	DASP-278	CN-S	CN64082
945582	DASP-279	CN-S	CN64083
945582	DASP-288	CN-S	CN64091
955582	DASP-289	CN-S	CN64090

955582	DASP-280	CN-E	CN64080
955582	DASP-281	CN-E	CN64081
955582	DASP-290	CN-E	CN64086
955582	DASP-291	CN-E	CN64087

Summary: DASP tooling used for Tie Out Anchor Spread and Anchor Squeeze has been revised for tools 317895 (Left Hand) and 317896 (Right Hand).

The revision removes .125" of material on the tool face closest to the rail. This change allows for greater possible clearance between the tools and the base of the rail.

Included in the tool change is an additional .125" thick shim which has been created (321502) to allow for finer adjustments than the currently equipped .25" thick shims.

Action: When ordering the following kits, they will now include the revised tooling and setup procedures. See 800258 instruction document.

- When ordering replacement tooling for existing kits or machines, it is recommended to also order the 321502 shim in addition to the tools.
- If the machine is already equipped with the 321502 .125" shim, re-ordering is not necessary.
- Note the revision of tool by looking at the stamped part number with the -X indicating revision. For example, tools stamped with: 317896-5 indicates revision 5.
- Existing Revision 4 tooling is still okay to use in rail environments where the extra clearance is not necessary.

For Gen-3 Combo Machines (914570) and Earlier:

- See Kit P/N 792985 to Convert DASP Tools to Anchor Squeeze
- See Kit P/N 792986 to Convert DASP Tools to Anchor Spread

For Gen-4 Combo Machines (93x582)

- See Kit P/N 793071 to Convert DASP Tools to Anchor Squeeze
- See Kit P/N 792986 to Convert DASP Tools to Anchor Spread

The Above Combo Machines

- The addition of the 321502 shim can be used to provide finer adjustments of a tighter clearance between tools and rail.

Completion / Resolution:

Update existing machines where extra clearance is needed. Continue normal machine operation after installation of new tooling and shims when needed.

Anchor Spread Tools

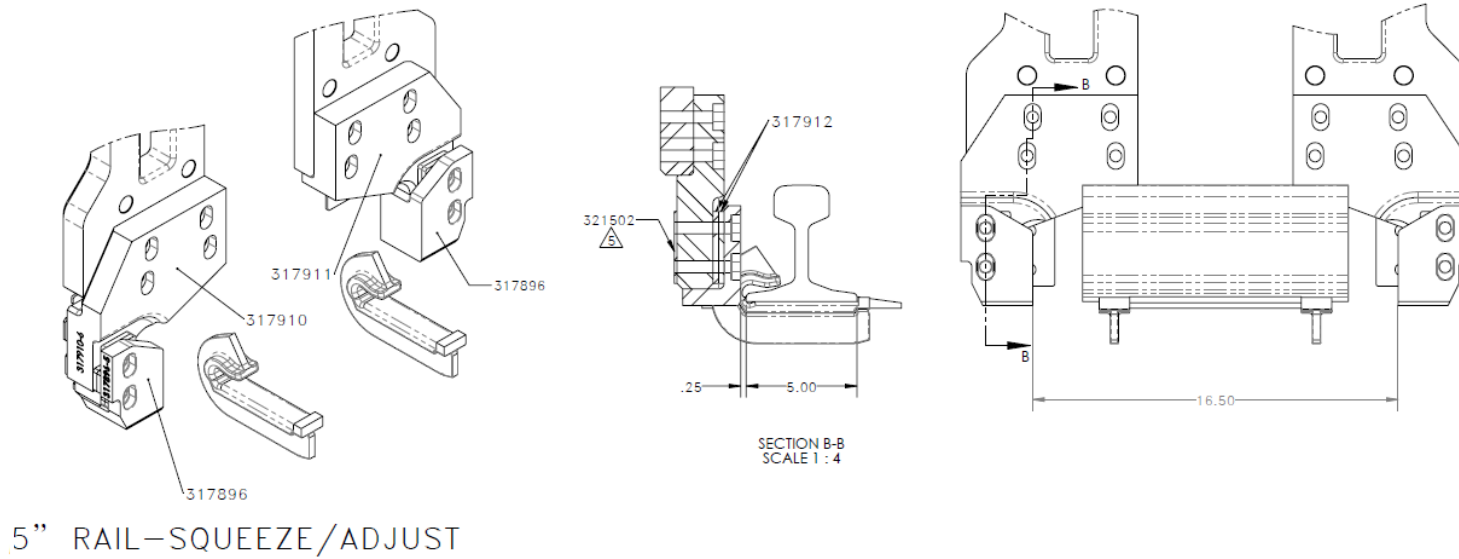

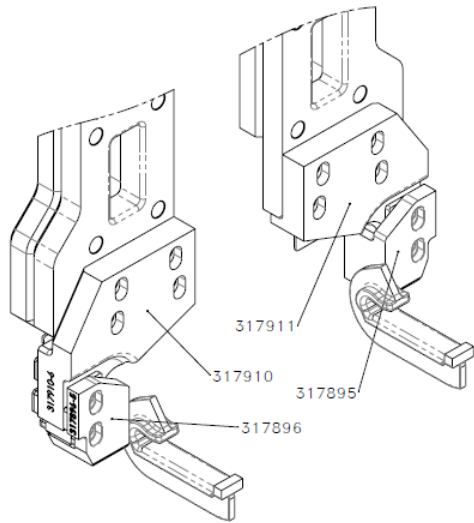

5.5" RAIL-SQUEEZE/ADJUST

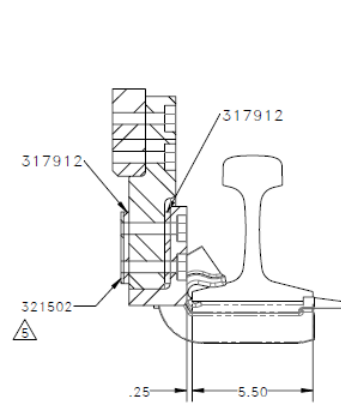

SECTION C-C
SCALE 1 : 4

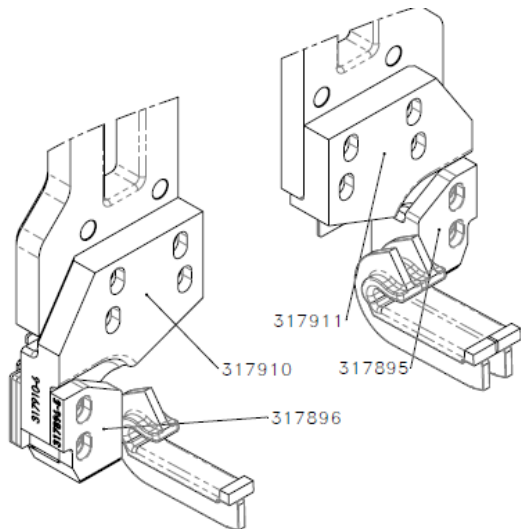
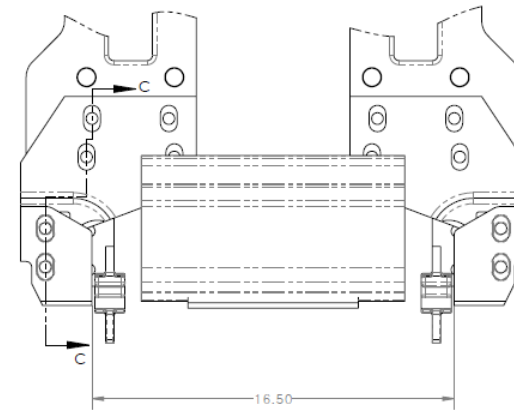

6" RAIL-SQUEEZE/ADJUST

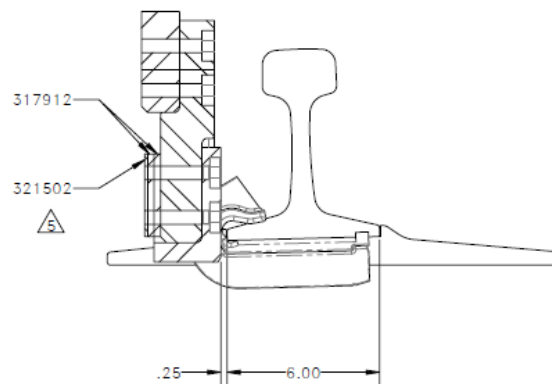

SECTION A-A
SCALE 1 : 4

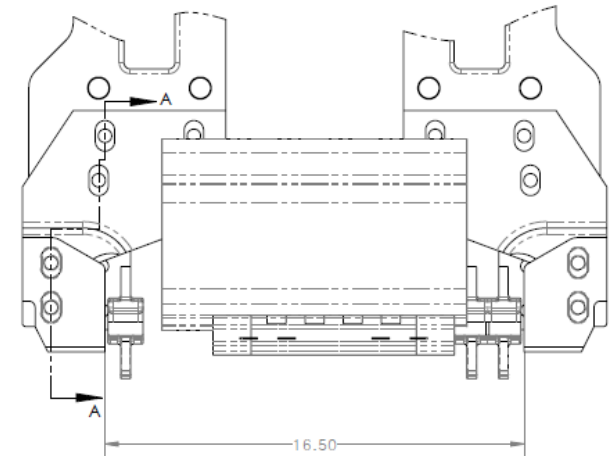

Anchor Adjust Tools: Rail – Spread

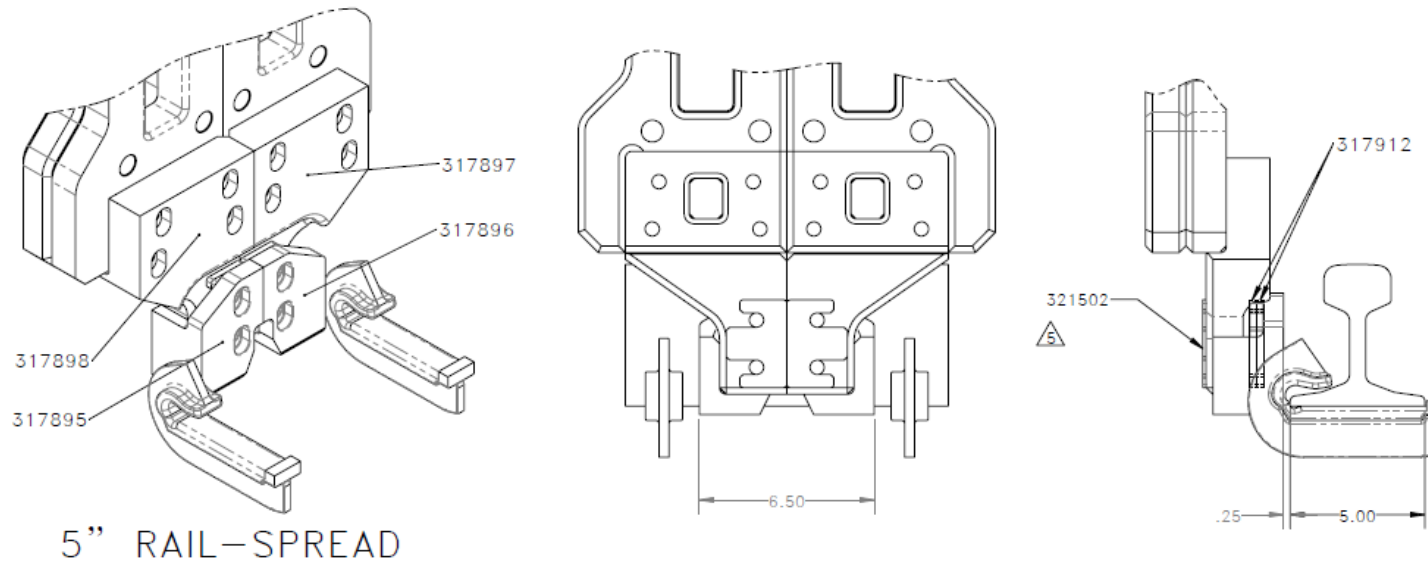

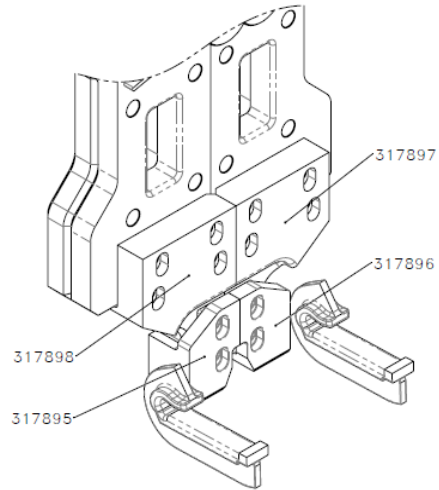

5.5" RAIL-SPREAD

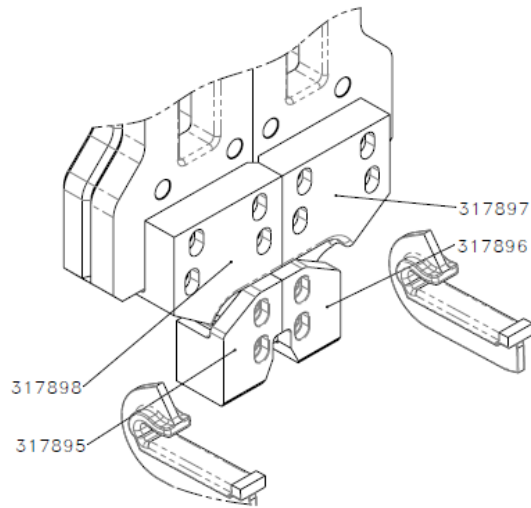
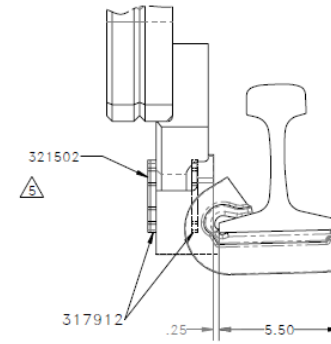
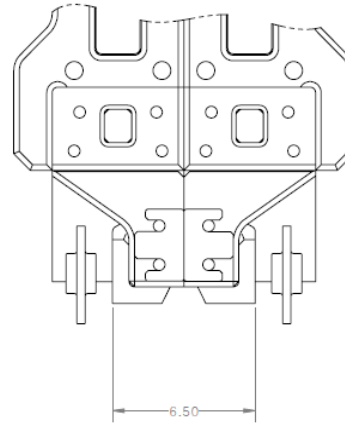

6" RAIL-SPREAD

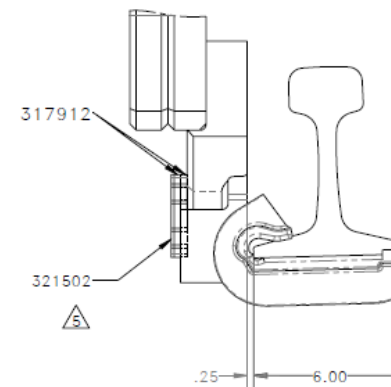
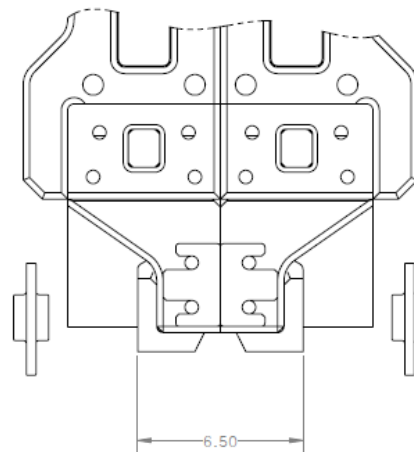

Anchor Adjust Tools: Rail – Squeeze/Adjust

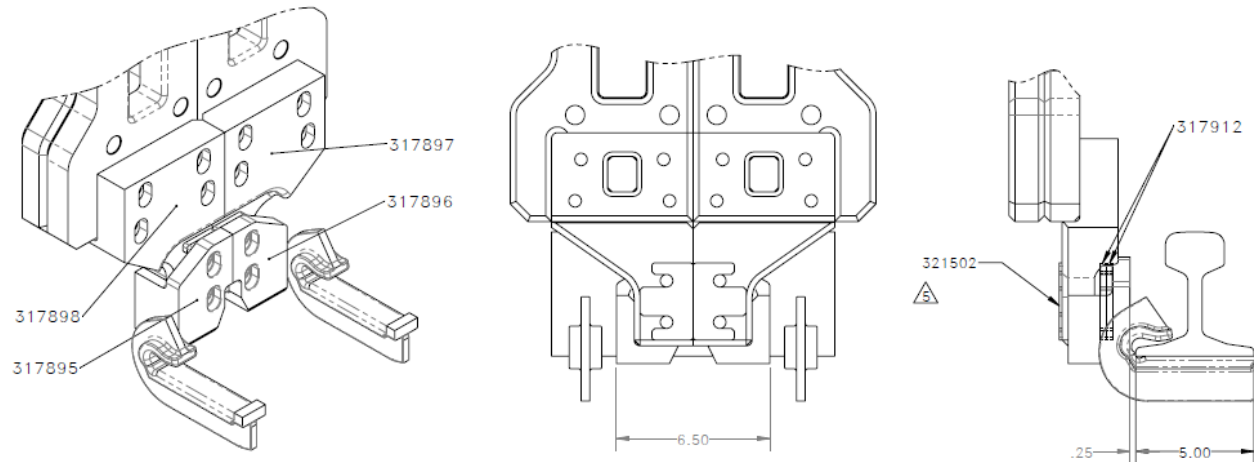

5" RAIL-SPREAD

sm

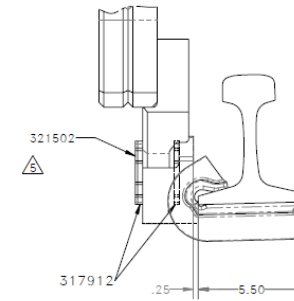
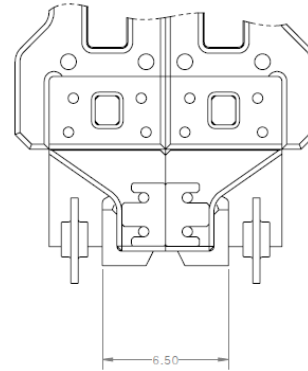
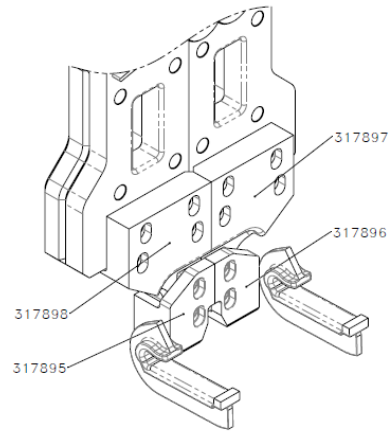

5.5" RAIL-SPREAD

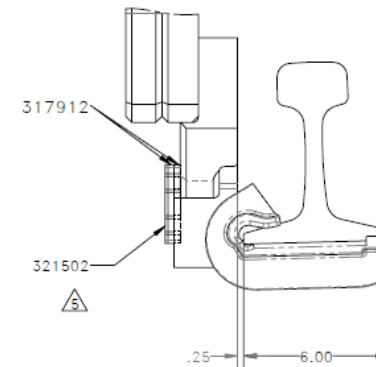
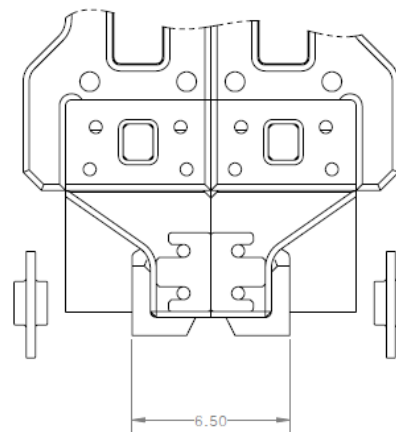
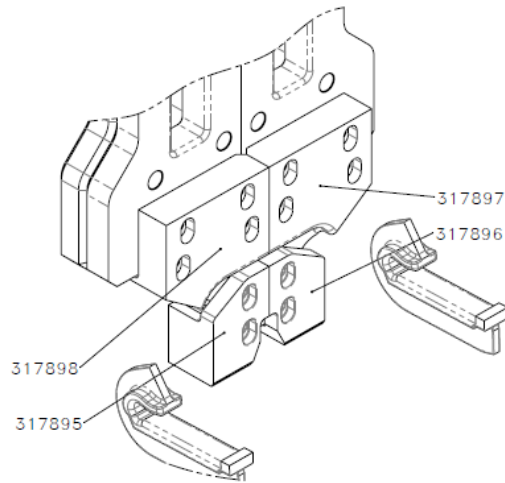

6" RAIL-SPREAD