

## Web Grinder

910106

## Operating and Maintenance Manual



---

# Web Grinder

## 910106

### Record of Changes

Rev No.	Date	Description of Changes
Rev 1	6.2012	Release
Rev 2	1.2019	Manual format & branding update, added assembly and parts list

## Table of Contents

Section 1: Overview and Safety .....	4
Web Grinder Overview .....	4
Warranty Terms and Conditions .....	4
Safety Information .....	6
Safety Terms .....	6
Machine Use and Safety Precautions .....	6
Section 2: Specifications and Installation.....	8
Specifications .....	8
Installation Instructions.....	10
Hose Requirements .....	11
Hose Types .....	11
Hydraulic Hose Recommendation .....	12
Hydraulic Fluid Recommendation .....	12
Hose Connecting Procedures .....	13
Disconnecting Hoses .....	14
Section 3: Tool Operation .....	15
Handle Adjustment.....	15
Tool Trigger and Trigger Lock .....	16
Wheel Guard and Wheel Installation .....	16
Positioning on Rail .....	18
Operation.....	18
Section 4: Maintenance.....	19
Troubleshooting .....	21
Section 5: Parts and Service Support .....	22
Technical Support & Service .....	22
Web Grinder Assembly .....	23
Web Grinder Parts List .....	25

## Section 1: Overview and Safety

### Web Grinder Overview

Racine Railroad Product designs and manufactures equipment primarily for the repair and new construction of rail and railroad tie track maintenance.

Our product line focuses on rail fastening application/removal/adjustment equipment, other tie material (OTM) reclamation, wood and concrete railway tie repair, and tie plate handling/distribution.

The Web Grinder is designed to remove excess material from the welded area on the web of the rail. When properly used this tool will help reduce back strain and reduce operator fatigue

- The Web Grinder mounts to the rail for stability and better control of the tool. The mounting system features a bearing roller for smooth operation.
- The adjustable handle allows the operator to set it in the most comfortable position for them to use.
- The two-position guard allows for the use of either 1" x 8" x 5/8" bore or 2" x 8" x 5/8" bore stones or wheels.
- The motor is operated by a trigger on the handle bar which when released, stops the rotation of the motor. The trigger features a lock system to prevent accidental activation.

### Warranty Terms and Conditions

#### Warranty Period

Each new machine and new parts of our manufacture are warranted against defects in material and workmanship for one year from the date of shipment from our factory.

When contacting customer service for factory parts, service or warranty support please provide the:

- Racine Railroad Products Model
- Serial Number
- Any locally assigned identification

#### Vendor Parts Warranty Period

Other equipment and parts used, but not manufactured by Racine Railroad Products, Inc., are covered directly by the manufacturer's warranty for their products.

#### Warranty Parts and Service

We will repair or replace, without charge, F.O.B. factory, Racine, Wisconsin, USA, any part Racine Railroad Products manufactures which is proven to be defective during the warranty period.

Material claimed defective must be returned, if requested, to the factory within 30 days from the date of the claim for replacement. Ordinary wear and tear, abuse, misuse and neglect are not covered by this warranty. Depending upon the circumstances, we may provide technical assistance and/or technical service support, without charge, to assist in the correction of warranty related problems.

## Non-Warranty Parts and Service

Material damaged through normal wear and tear, abuse, misuse and/or neglect are not covered by our warranty and should be ordered directly from our Customer Service.

**Note:** Parts for models that are no longer in production may not be available.

## Non-Warranty Parts Orders

When placing a parts order please provide the following information:

- Company Name and Billing Address
- Purchase Order Number and Issuing Authority
- Shipping Address
- Special Handling Instructions
- Contact Phone Number
- Machine Model and Serial Number
- Part Numbers and Quantities Being Ordered

**Note:** *Please use Racine Railroad Products part numbers when ordering parts.* Racine Railroad Products part numbers are shown in the parts lists and drawings of this manual and have only six (6) numbers.

Any part number with other than six numbers (e.g. contains alpha-numeric characters) is a Vendor Part Number and **not** a Racine Railroad Products part number

## Safety Information

For safe installation and operation of this equipment, carefully read and understand the contents of this manual. Improper operation, handling, or maintenance can result in equipment damage and personal injury.

Only trained and authorized personnel should be allowed to operate this machine. In addition, all personnel at the worksite (gang) should be aware of the safety concerns and their individual responsibilities prior to working this machine.

Please read and comply with all the safety precautions in this manual **before** operating this machine. Your safety is at risk.

## Safety Terms



**DANGER** indicates a hazardous operating procedure, practice, or condition. If the hazardous situation is not avoided death or serious injury will occur.



**WARNING** indicates a hazardous operating procedure, practice, or condition. If the hazardous situation is not avoided death or serious injury could occur.



**CAUTION** indicates a potentially hazardous operating procedure, practice, or condition. If the hazardous situation is not moderate or minor injury could occur.

**Note:** Indicates an essential operating procedure, practice, or condition. No personal injury is possible.

## Machine Use and Safety Precautions



**Failure to follow safety precautions when operating this equipment can result in serious injury or death to the operator or other persons in the area.**

**Observe the following precautions whenever you are operating, working on or near this equipment.**

**Do not** use this machine for other than its intended purpose.

**Do not** make any modifications without authorization or written approval from Racine Railroad Products. Replace all Racine Railroad Products and OEM parts with genuine Racine Railroad Products and OEM parts. Using non-OEM parts may compromise the safety of the machine.

**Do not** wear loose clothing, jewelry, radio belts, etc., when operating, working on or near this equipment. They can be caught in moving parts and may result in severe injury.

**Do not** allow others to be near the tool when starting it or while operating. Keep bystanders and animals out of the work area.

**Do not** overreach. Maintain proper footing and balance at all times.

**Never** operate the tool when you are tired, angry, emotionally disturbed, or under the influence of alcohol, drugs, medications, or anything that could affect your vision, alertness, coordination or judgement.

**Always** wear appropriate personal protective clothing when operating this equipment: e.g. Orange safety vest, hard hat, safety glasses with side shields, hearing protection, steel-toed safety boots, leather gloves, dust respirator, etc.

**Always** lift heavy objects with the knees and legs, not the arms and back.

**Always** keep hands, arms, feet, head, clothing, etc., out of the operating area and away from all rotating or moving components when operating, working on or near this machine.

**Always** make sure that all guards, covers, belts, hoses and operating components are in good working order and that all controls are in the appropriate position before starting the engine.

**Always** make sure that all safety equipment installed properly and are in good working order. Do not operate the machine until unsafe conditions have been corrected.

**Always** operate in a well-ventilated area and make sure that the air filters, air filter covers, and muffler are in good condition.

**Always** keep the machine clean and free of debris. Operate the machine in a safe and responsible manner. Exercise caution when fueling, working on or near rotating or moving components, hot components and fuel systems. Be aware of potential fire hazards and prevent sparks, exhaust, etc., from starting fires on the machine and/or work area.

**Always** hold the tool with both hands, using a firm grip when activating and operating.

**Always** comply with all instructions provided on any decals or placards installed on the machine and with any relevant amplifying information provided in this manual or other general operating procedures.

**Always** shut disconnect the power source and make sure that all controls are in a safe position and install all appropriate locking and safety devices before doing any of the following:

- Lubricating
- Adjusting
- Installing Tooling
- Making Repairs
- Performing Service

### **Stone / Wheel Safety**

**Always** remove wheel from the tool during transportation and storage.

**Always** use wheels that meet the minimum requirements of the tool.

**Do not** cock, wedge, or jam the wheel in a cut.

**Do not** use the tool if the wheel doesn't stop turning when the trigger is released.

**Do not** exceed the tool's maximum speed rating.

**Do not** reverse the tool rotation.

**Inspect** the wheel before operating the tool. Do not use damaged wheels.

**Make sure** the grinding wheel has stopped turning before removing the tool from the rail.

**Never** carry the tool with the wheel turning.

## Section 2: Specifications and Installation

### Specifications

Hydraulic System	Open Center
Frame Type	Tube
Length	47 in. [119.38 cm]
Width	29 in. [73.66 cm]
Height (Adjustable)	27-38 in. [68.58 – 96.52 cm]
Weight (Less Stone)	34 lbs [15.42 kg]
Circuit	10 GPM @ 2000 psi 38 LPM @ 138 bar

#### Hydraulic Fluid Requirements [Viscosity (Fluid Thickness)]

USA	Metric
50° F 450 SSU Max	10° C 95 Centistokes
100° F 130-200 SSU	38° C 27-42 C.S.
140° F 85 SSU Min.	60° C 16.5 C.S., Min.

Pour Point ..... 10° F / 23° C Minimum (for cold startup)

Viscosity Index (ASTM D 2220)..... 140° F Minimum

Demulsibility (ASTM D-1401) ..... 30 Minutes Maximum

Flash Point (ASTM D-92) ..... 340° F / 171° C Minimum

Rust Inhibition (ASTM D-665 A & B) ... Pass

Oxidation (ASTM D943) ..... 1000 Hours Minimum

Pump Wear Test (ASTM D2882)..... 60 mg Maximum



**Power Unit Requirements**

- The power source must provide a flow of 8 – 10 GPM / 30 – 38 LPM at 1500 – 2000 psi / 100 – 400 bar.
- A relief valve setting between 2100 – 2250 psi / 145 – 155 bar is required for the operation of this tool.
- The hydraulic system's back pressure should be less than 250 psi / 17 bar, measured at the tool end of the operating hoses. All system checks should be made at a minimum operating temperature 100 °F / 38 °C (maximum fluid viscosity of 400 ssu / 82 centistoke).
- The hydraulic fluid cooling system should limit the maximum temperature to 140 °F / 60 °C at the maximum expected ambient temperature.
- The minimum cooling capacity should be 5 hp / 3.73 kW at a 40 °F / 22 °C difference between ambient temperature and fluid temperature.
- A minimum of 25-micron filtration is required for the hydraulic system. For cold weather startup and maximum dirt holding capacity a filter element sized for 30 GPM / 14 LPM is recommended.
- Racine Railroad Products recommends the use of the Diesel Power Unit. The Diesel Power Unit is a versatile power unit that can meet the needs for most hydraulic tools used by the rail road industry.

This power unit is capable of powering two tools simultaneously at 5 GPM (20 LPM) or one tool a 10 GPM (40 LPM) all the flows are at 200 psi / 138 bar. The maximum pressure of the hydraulic system is limited to 2150 psi / 148.3 bar.

The power source provides the required flow and pressure to operated HTMA type I 15 – 23 LPM (4 – 6 GPM) and type RR 34 – 40 LPM (9 – 10.5) tools. All which are open-center tools required an operating pressure of 2000 psi / 138 bar.

## Installation Instructions

### Unpacking Instructions

Upon receiving your Web Grinder promptly remove it from the shipping container. Always keep top side of container up. Inspect unit for damage which may have incurred during shipping and report it to carrier for claim.

### Tool Preparations

Some Web Grinder are shipped with the handles removed from the frame to conserve space.

If your web grinder is shipped in this manner, insert the handle tube into the frame and tighten the locking lever to secure the handle in place.

When inserting the handle, avoid kinking the hoses, they should flow in a hanging arc from the motor to the handle.

Web grinders are shipped without grinding stones, unless otherwise requested, so a stone will need to be installed before operation.



Hydraulic fluids are thicker in cold weather; therefore, run the engine at low idle long enough to bring the fluid temperature up to minimum of 10°C/50 F or until the top of the hydraulic tank feels warm, before operating tool.



**Never stick foreign objects, fingers, or other extremities into moving mechanism. Failure to follow these instructions may lead to severe personal injury or tool damage.**

### Testing

Before operating the Web Grinder it is important to inspect the grinding wheel for damage, replace as required. Check that all guards are securely in place before operating the tool. Follow all safety precautions when inspecting tool.

All testing must be done by a trained technician.

1. To test the web grinder, apply a thin strip of masking tape to the outer edge of the grinding stone.
2. Secure the grinder by clamping it in a vice or other suitable device with the stone positioned clear of any objects.
3. Connect the tool to a suitable power source. See *Hose Connecting Procedures* section for installation details.
4. Engage the trigger and run the grinder at maximum speed.
5. Use a strobe light tachometer to measure the RPM's.
  - The wheel should be rotating between 3300 rpms and 3700 rpms.
  - If the RPM's do not fall in this range, see *Troubleshooting* in the Maintenance section.
6. When testing is complete, disconnect the tool from the power source and remove it from the vice.



**When testing the lock installer, follow all safety guidelines.**

## Hose Requirements

It is not often necessary or advisable to use long hoses. All hoses must have an oil resistant inner surface and an abrasion resistant outer surface. Each hose must have male pipe ends for most application.

Longer hoses can be used when necessary but can affect the operation of the tool due to resistance in the hose.

If small diameter or long hoses are used, or if restrictive fittings are connected to the supply and return ports, the pressure required to push the fluid through the system and back to the tank will be higher. This will reduce tool power.

**Important:** Oil should always flow from the male coupler through the female coupler.

**Note:** The pressure increases in uncoupled hoses left in the sun. This may make them difficult to connect. When possible after use, connect the free ends of the operating hoses together.

## Hose Types

Hydraulic hose types authorized for use with the Web Grinder are:

1. Labeled and certified nonconductive.
  - This is the only hose authorized for use near electrical conductors.
2. Wire braided (conductive)
  - This hose is conductive and must never be used near electrical conductors.
3. Fabric braided (not certified or labeled non-conductive)
  - This hose is conductive and must never be used near electrical conductors.

The rated working pressure of the hydraulic hose must be at least 175 bar (2500 psi).

## Hydraulic Hose Recommendation

Hydraulic Hose Recommendation								
Flow Per Circuit		Length Each Hose		Use	Inside Diameter		SAE Spec Hose (Wire Braid)	SAE Spec Hose (Fiber Braid)
GPM	LPM	Feet	Meter		Inch	MM		
5 to 8	19 to 30	To 50	To 15	Both	1/2	13	SAE 100R1-8	100R7-8
5 to 8	19 to 30	51 to 100	15 to 30	Both	5/8	16	SAE 100R2-10	SAE 100R8-10
5 to 8	19 to 30	100 to 300	30 to 90	Pressure Return	5/8 3/4	16 19	SAE 100R2-10 SAE 100R1-12	SAE 100R8-10 SAE 100R7-12
9 to 12	34 to 45	To 50	To 15	Both	5/8	16	SAE 100R2-10	SAE 100R8-10
9 v 12	34 to 45	51 to 100	15 to 30	Pressure Return	5/8 3/4	16 19	SAE 100R2-10 SAE 100R3-12	SAE 100R8-10 SAE 100R7-12
9 to 12	24 to 45	100 to 200	30 to 60	Pressure Return	3/4 1	19 25.4	SAE 100R2-12 SAE 100R1-16	SAE 100R8-12 SAE100R7-16

The rated working pressure of the hydraulic hose must be at least 2500 psi / 173 bar.

## Hydraulic Fluid Recommendation

Inspect hoses for cuts, crushing, leaks, or abrasion, which may be a safety hazard or reduce fluid flows.

The following fluids work well over a wide temperature range at startup, allow moisture to settle out, and resist biological growth likely in cool operating hydraulic circuits.

Others that meet or exceeds the specifications of these fluids may also be used.

Type	Hydraulic fluid
Chevron	Clarity AW 15032
Exxon	Univis J 32
Mobil	D.T.E. 13M
Gulf	Harmony AW-HVI-150-32
Shell	Tellus T 32
Texaco	Rando HDZ 32
Union	Unax AW-WR-32
Amsoil	AWH 15032
Sunvis	Low Pour H/032-product code 19300

## Hose Connecting Procedures

1. Stop the engine before connecting the tool and or hoses to the OFF power unit, and when switching hoses or tools.
2. Turn the hydraulic on/off valve to the off position before starting the engine.

Make sure all hoses are connected for correct flow direction to and from the tool being used.

When routing hose in the work area, position them where personnel will not be at risk of tripping over them where vehicles can run over the hoses. Do not lay hose over sharp objects.



**Pressurized fluid escaping from a damaged hose can penetrate the skin and be injected in the body causing injury or death.**

**Do not pull on hoses to drag the power unit or tool.**

### Connecting Hoses

1. Wipe quick couplers with a clean lint free cloth before connecting them.
2. Depressurize the system.
3. Allow system and hydraulic fluid to cool if too hot to handle.
4. Securely connect the return (tank “R”) hose from the power source to the tool.
5. Securely connect the supply (pressure “P”) hose from the power source to the tool.

It is recommended that you connect the return hoses first and disconnect last to minimize or avoid trapping pressure within the tool.

When connecting the quick couplers, the flow should run from male coupler to the female coupler. The female coupler on the tool is the inlet. Quick couplers are marked with a flow direction arrow.



**Pressurized fluid escaping from a damaged hose can penetrate the skin and be injected in the body causing injury or death.**

**Do not pull on hoses to drag the power unit or tool.**

**Note:** When possible, connect the free ends of uncoupled hoses to prevent build up in the hoses. The sun can also increase pressure in the hoses and make connecting them difficult.

1. Grip the handles firmly with both hands.
2. Pull down with thumb on the safety lock and pull the trigger to the handle to start the grinder.
3. When starting the tool, hold it off from all surfaces.
4. Start grinding with the tool running.
5. When finished, release trigger and allow stone to stop turning and make sure trigger is in the locked position before placing the tool on any surface.

## Disconnecting Hoses

1. Stop the hydraulic power source.
2. Depressurize the system.
3. Allow system and hydraulic fluid to cool.
4. Disconnect the supply (pressure) hose to the power source (pressure port) from the tool (IN port).
5. Disconnect the return (tank) hose to the hydraulic power source (return port) from the tool (OUT port).
6. To prevent contamination, always install dust caps over the hydraulic ports of the tool when disconnected.



### **WARNING**

**If injury results from escaping hydraulic fluid, seek immediate medical attention. Serious bodily injury may occur if proper medical attention is not administered immediately.**

**Do not attempt to locate hydraulic leaks by feeling around hoses and fittings with your hands. Pinhole leaks can penetrate the skin.**

## Section 3: Tool Operation

### Handle Adjustment

The Web Grinder is operated from a T-handle.

On the T-handle there is a trigger that is used to engage the grinder.

- When the trigger is drawn to the handle the trigger link then activates the on/off valve and starts the grinder wheel spinning.
- When the trigger is released the grinder wheel will stop rotating.

The handle height can be adjusted to accommodate the operator's comfort zone.

Loosen the locking lever on the frame, adjust the handle height, and tighten the lever to lock handle in place.

The handle position can also be rotated 90-degrees by loosening the locking lever and lifting the handle out of the frame.

1. Turn the handle 90-degrees.
2. Insert the handle back into the frame.
3. Tighten the locking lever to secure handle.

The guide roller has bearings for smooth, effortless motion when grinding.

### Stone / Wheel Guard

The Web Grinder's 2-position Guard can house either 1" or 2" grinding stones / wheels.

A locking spindle holds shaft in position to aid in stone removal.

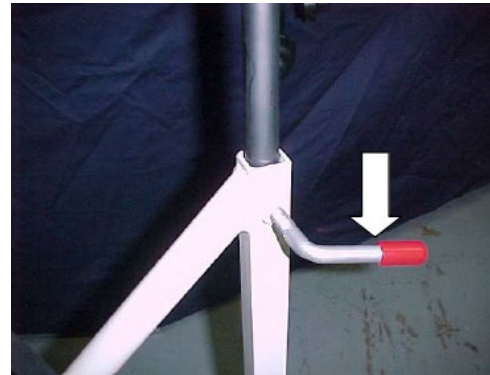

Locking Lever



Guide Roller

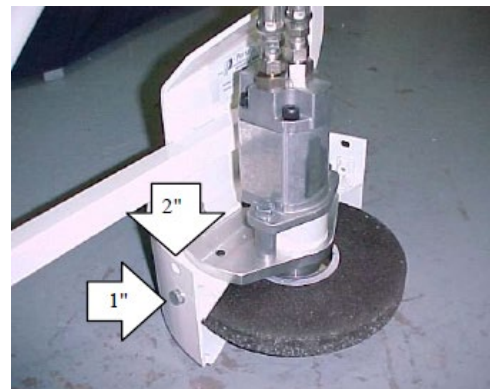

2-Position Guard

## Tool Trigger and Trigger Lock

1. Check that trigger lock presses into handle tube easily and returns to locking position when released (Arrow A).
2. Check that trigger cannot be activated with the trigger lock in the released position.
3. With the trigger lock pressed into the handle tube, pull the trigger to the tube.

The trigger should return to the OFF position when released (Arrow B).

If the trigger or trigger stop sticks or does not operate easily, check for obstructions.

If the trigger lock does not return to the OFF or lock position when released, check the return springs.

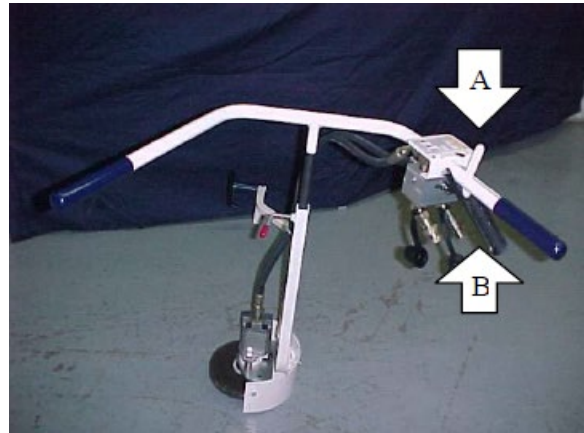

## Wheel Guard and Wheel Installation



### WARNING

**Do not operate a tool if the trigger or trigger lock is not working properly. Failure to follow these instructions may lead to severe personal injury.**

**Do not operate tool without the wheel guard in place. Failure to follow these instructions may lead to severe personal injury.**

Inspect the wheel guard and fasteners for damage. Repair any damage before using the tool.

### Wheel inspection

Before mounting all wheels should be visually inspected by the operator for damage and cracks.

**Do not use damaged or cracked wheels.**

A Ring Test may be used to check for cracks in the wheel, which are not visible to the naked eye.

1. To perform a Ring Test, suspend the wheel from the hole on a small pin or finger.
2. Tap the wheel gently with a non-metallic implement such as a screwdriver handle.
3. The best spot to tap is about 45-degrees either side of the vertical center ling 1" or 2" from the periphery.
  - An undamaged wheel will give a clear tone.
  - If cracked there will be a dead sound instead.

Check that the surface of the blotters and backups are free of dirt and other foreign contaminants.

Use only wheels, which meet or exceed the requirements of the tool.

### Wheel Backups

Inspect the backup hole and flange before installation. The backup should be free of burrs and the bearing surfaces flat and running true when mounted on the drive spindle.



## Reducing Bushings

If reducing bushings are used in a wheel's mounting hole, check that it does not protrude beyond the surface of the wheel. Bushings that are too thick will not allow the backups to contact the wheel properly.

Do not use wheels that have bushings which are loose in the mounting holes. Do not use shim stock to tighten or replace bushings.

## Wheel Installation

1. Remove the stone guard.
2. Hold the spindle lock pin in while turning the spindle shaft or stone counter-clockwise (left) until the stops the shaft.

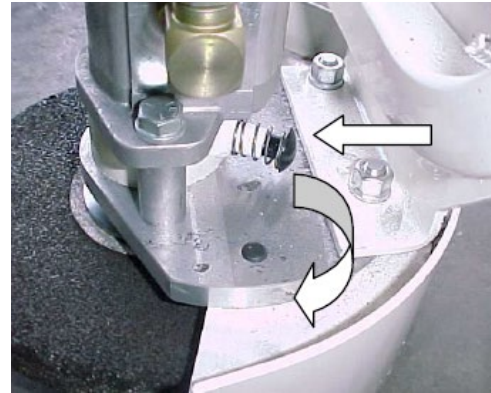

Spindle Lock Pin

3. Holding the pin in, apply enough force to loosen the retaining nut and remove it (Arrow A).
4. Remove the backup flange and used grinding stone (Arrow B).
5. Check that the blotter came off with the stone and did not stick to the inner backup.
6. Check that the inside backup stayed in place. The square on the spindle should slide into the square in the back of the backup.
7. Use new blotters between the stone and backups.
  - The blotters should be supplied with the stones.
  - They are made from highly compressible material and should not be more than .025 inches thick.
8. Place the stone and outer backup on the spindle and tighten the retaining nut.
9. Install the stone / wheel guard in the proper location for 1" or 2" thick grinding stones.
10. Before starting grinder make sure the locking pin has return to the unlock position and the stone turns easily by hand.

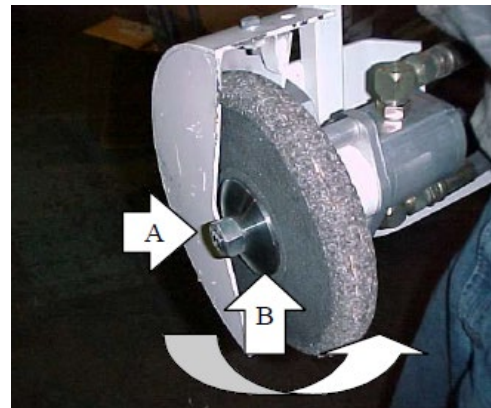

Retaining Nut

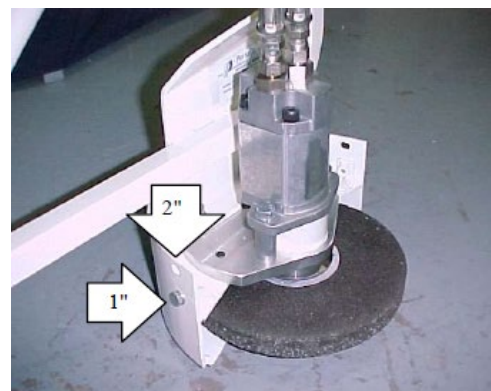

Stone / Wheel Guard

## Positioning on Rail

When positioning on the rail, the Web Grinder frame should start out at a slight angle to the rail.

1. Set the roller end over the ball of the rail so the end hook drops below the ball.
2. With the hook under the rail, bring the Web Grinder towards the rail letting the roller rest on top of the ball.
3. The roller end has now captured the ball of the rail and will not jump off. (Figure 3.6B)



Frame at a slight angle to the rail.



Web Grinder on the rail.

## Operation

1. Connect the hoses. See *Hose Connecting Procedures* for details.
2. Position web grinder on the rail.
3. Firmly grip the handle bars of the Web Grinder and hold the stone off the ground a short distance from the web of the rail.
4. Press the trigger lock down and pull the trigger to turn grinder ON. The trigger must be held in the on position while grinding.
5. Move the grinder as required to grind the weld.
6. When grinding job has been completed release the trigger. The stone will stop turning.
7. Make sure the stone has stopped before removing grinder from the rail.
8. Disconnect the hoses.

## Section 4: Maintenance

It is highly recommended to practice regular check-ups and maintenance in accordance with the usage frequency to keep your tool in better condition and reduces total running costs.



**Do not perform maintenance on the Web Grinder while the hydraulic power source motor is running or when hoses are connected.**

**All maintenance must be done with the tool disconnected from power source.**

### Cleaning and Maintenance Recommendations

- Wipe all external surfaces after each use with a clean, lint free cloth to remove surface contaminants from the tool.
- Store all tools in an enclosed area to prevent weather from contaminating their systems.

### Safety Devices

When maintenance is complete, make sure the following:

- The hydraulic control valves are operable.
- The hydraulic quick couplers and hoses are safe to use.

### Storage Preparation

- Cover male and female hose whips.
- Store in the upright position. Secure tool to prevent it from being knocked over.
- Store the Web Grinder on a smooth level surface.
- The tool should be stored in a cool, dry environment which is not subjected to rapid temperature changes.
- When storing tool for extend length of time it is recommended that the grinding stone be removed. Grinding stones, which are not stored properly increase the potential for them to fail when put into use

### Daily



**Do not attempt to locate hydraulic leaks by feeling around hoses and fitting with hand. Pin-Hole leaks can penetrate the skin.**

- Wipe all tool surfaces, fittings, and couplings free of grease, dirt, and foreign materials.
- Inspect the tool, hydraulic system, hoses, and fittings for signs of leaks, cracks, wear, and/or damage. Replace if necessary.
- To prevent contamination, always install dust caps over the hydraulic ports when disconnected.
- Inspect grinder stone for damage and wear, replace as required.
- Inspect stone guard fasteners. Keep fasteners tight and guard in good condition.

**Monthly**

- Perform a detailed inspection of the systems hoses and fittings according to the hydraulic hose operator’s manual and as stated in SAE standard j1273, May 1989 or latest revision.

Replace the hoses and/or fittings if necessary.

**Care for Abrasive Wheels**

All abrasive wheels are breakable and therefore care should be exercised in handling and storage to prevent damage.

All abrasive wheels should be stored in a dry area and not be subjected to exposure to water or other solvents. Also avoid freezing temperatures and humid conditions which cause condensation on the wheels.

Thin organic bonded wheels, (rail saw blades or slotting discs used for cutting), should be laid flat on a flat surface of steel or similar rigid material away from excessive heat, moisture, and other liquids.

If thin wheels are supplied with blotters attached, suitable separators should be used to preserve flatness.

**Coupler Recommendation**

3/8 inch Flat Face HTMA couplers rated at 2500 psi working pressure. Threads are to match fittings used on hoses or fittings used as adapters.

<b>Bolt Size</b>	<b>Torque</b>
#10-32	38 in-lb
1/4-20	76 in-lb
5/16-18	13 ft-lb
3/8-16	23 ft-lb

## Troubleshooting

The following chart can be used as a guide to correct any problem you may experience with the tool.

To determine the problem in operation of the lag driver always check that the hydraulic power source is supplying the correct hydraulic flow and pressure to the tool as listed in the table. Be sure you are using an accurate flow meter. Check the flow with the hydraulic fluid temperature at least 80° F / 27° C.

**Note:** Stop and depressurize the hydraulic system before connecting or disconnecting a tool.

Failure to follow these instructions can lead to severe personal injury. Read and follow the instructions in this manual for the proper way to connect and disconnect tools from the hydraulic systems.

Problem	Cause	Remedy
Tool will not run.	Power source	Check power source flows and pressure. 8-10 gpm / 30-38 lpm at 2000 psi / 150 bar.
	Coupler or hose.	Check for /remove obstruction.
	Mechanical failure	Disassemble tool and check for damage.
Tool runs backwards.	Pressure and return reversed.	Correct hose connection or flow direction. Motor shaft rotates counter-clockwise as viewed from the end of the shaft.
Hydraulic fluid leaks from spindle.	Damaged motor seal.	Disassemble tool and replace seal.
Grinds too slow.	Insufficient fluid flow or low relief valve setting.	Adjust flow to proper gpm. For best performance adjust relief valve to 2100-2250 psi / 145-155 bar.
Trigger (ON/OFF) hard to press.	Back pressure too high.	Should not exceed 250 psi / 17 bar at 10 gpm / 38 lpm.
	Pressure and return reversed.	Correct for proper flow direction
	ON/OFF mechanism blocked.	check on/off mechanism remove obstruction if present.

---

## Section 5: Parts and Service Support

### Technical Support & Service

Telephone and web-based technical support is available for current production models through our Technical Service Department. Service Manuals and limited technical support may be available for models that are no longer in production.

#### Telephone and E-mail Technical Support

Telephone and E-mail technical support is available on normal U.S. business days from 8:00 AM to 5:00 PM U.S. Central Time Zone (GMT +6 (+5 Daylight Savings Time)). Contact us at:

Phone: (262) 637-9681

E-mail: [techserv@racinerailroad.com](mailto:techserv@racinerailroad.com)

#### Non-Warranty Technical or Field Service Support

Depending upon the circumstances and availability of technical service personnel, we may provide technical assistance and/or field service support, *at the customer's expense*, to assist in the correction of non-warranty related problems. Contact our Technical Service Department to coordinate Non-Warranty Technical or Field Service Support.

#### Warranty Technical or Field Service Support

Depending upon the circumstances and availability of technical service personnel, we may provide technical assistance and/or field service support, *at no charge to the customer*, to assist in the correction of warranty related problems. Contact our Technical Service Department to coordinate Warranty Technical or Field Service Support.

#### Warranty Parts & Service

Warranty parts and service are coordinated through our Technical Service Department.

#### Warranty Parts Claims

Material claimed to be defective must be returned to our factory for evaluation. Defective materials will be replaced, or your account will be credited if replacement materials have already been purchased. Please contact our Technical Service Department at the address provided below if you have any questions or problems.

#### Warranty Service Support

Depending upon the circumstances and availability of technical service personnel, we may provide technical assistance and/or field service support, at no charge to the customer, to assist in the correction of warranty related problems. Contact our Technical Service Department at the address provided below to coordinate Warranty Technical or Field Service Support.

**Web Grinder Assembly**

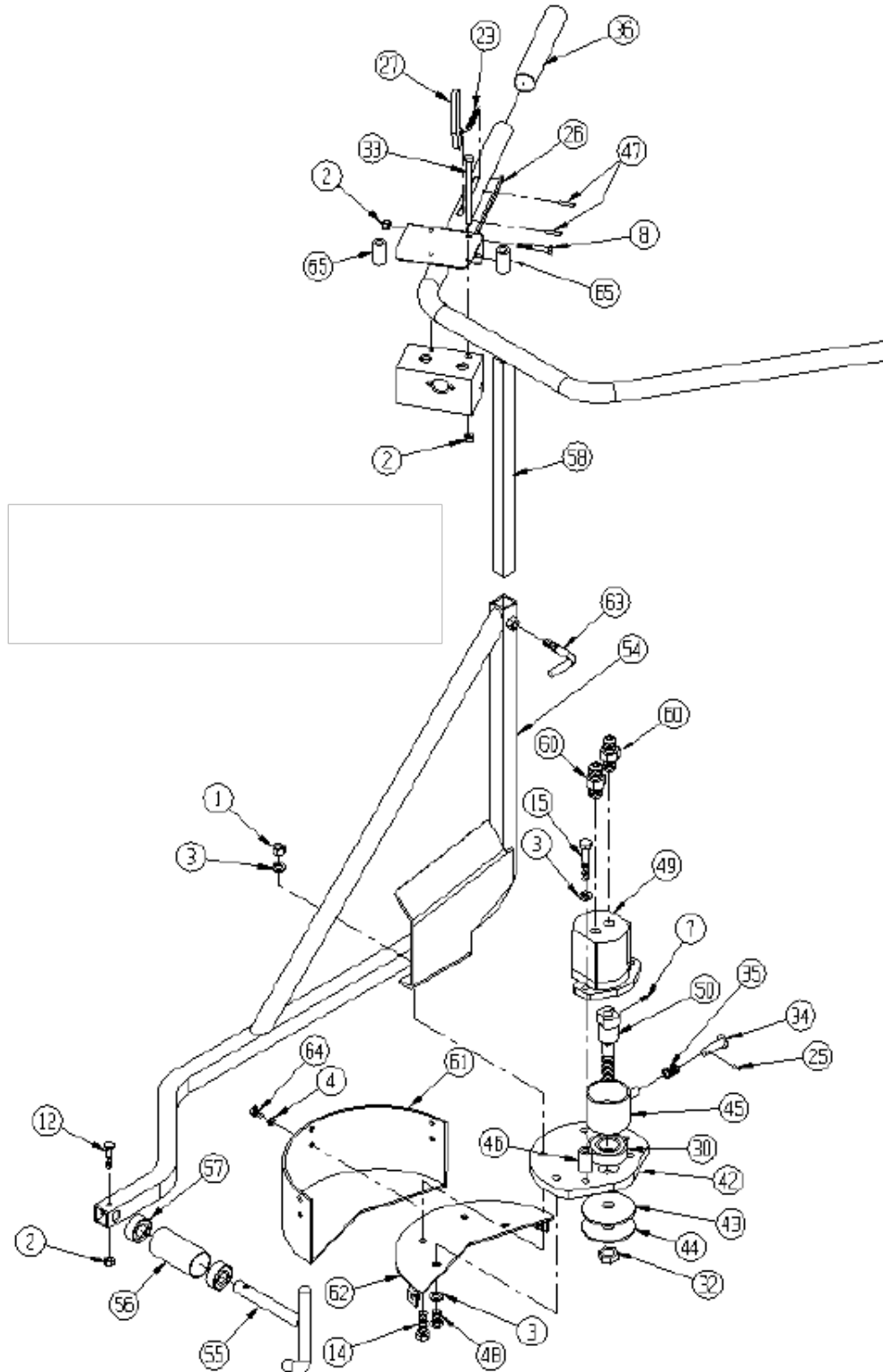

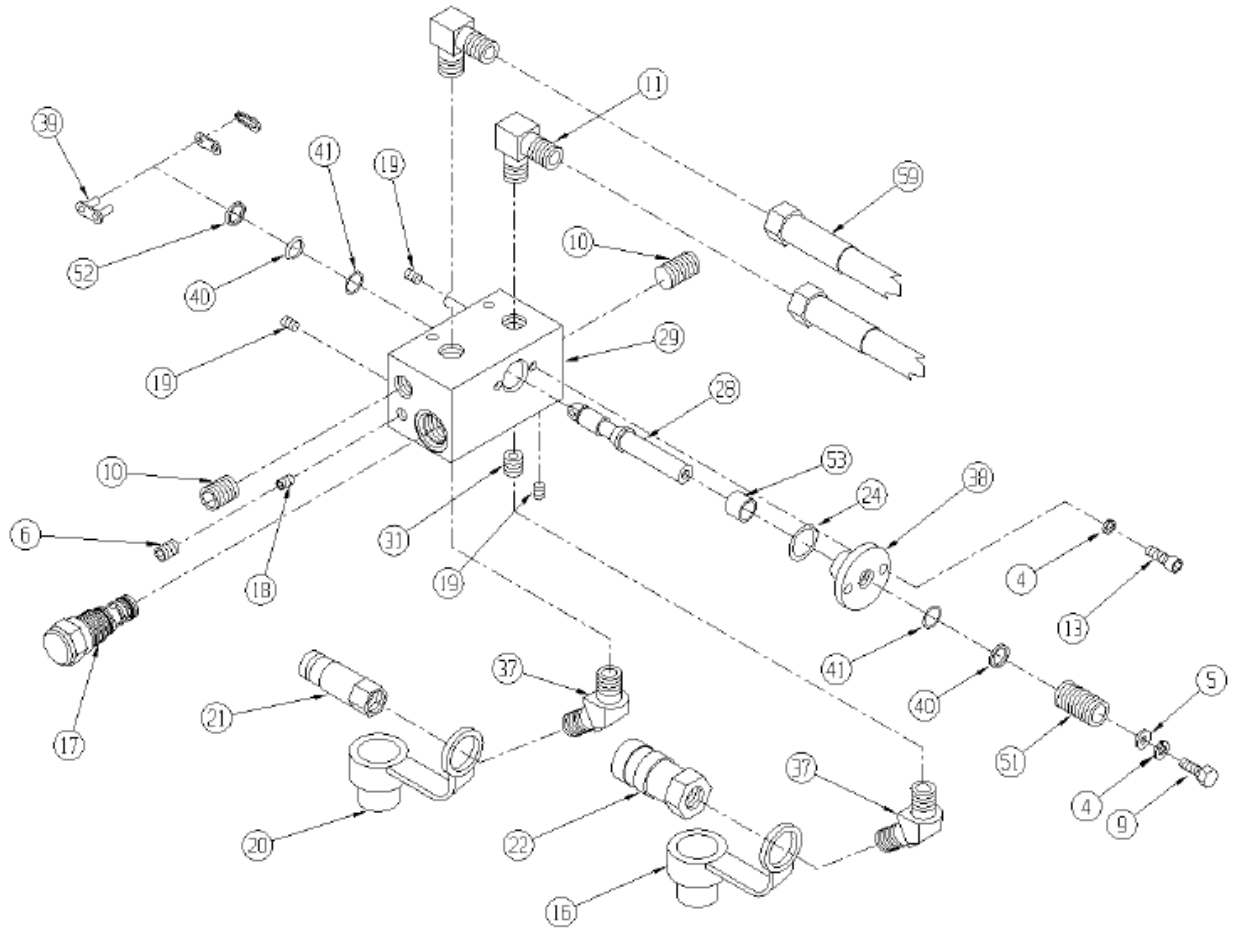



**Web Grinder Parts List**

Item No.	RRP Part Number	Description	Qty
1	401046	NUT 3/8	2
2	404549	NUT ¼ NC NYLOCK	4
3	400907	3/8 LOCK WASHER	6
4	400906	1/4 LOCK WASHER	5
5	401619	WASHER, FLAT 1/4 PLATED	1
6	400922	PLUG	1
7		SET SCREW	1
8	400690	BOLT 1/4 NC X 1 ¾	1
9	400686	BOLT 1/4nc X 1/2"	1
10	469854	PLUG	
11	459997	FITTING 90°	2
12	400687	BOLT 1/4 NC X 1 1/4	1
13	400686	BOLT 1/2 NC X 3/4	2
14	400713	BOLT 3/8 NC X 1 1/4	2
15	400716	BOLT 3/3 NC X 2	2
16		COVER COUPLER	1
17	467724	VALVE	1
18	469855	ORIFACE	1
19	10000346	PLUG 1/16 NPT	3
20		COVER COUPLER	1
21		COUPLER FEMALE	1
22		COUPLER MALE	1
23	466534	SPRING RETURN	1
24	468767	O-RING	1
25	467698	ROLL PIN	1
26		TRIGGER VALVE	1
27		TRIGGER SAFETY STOP	1
28	468768	SPOOL VALVE	1
29	468769	MANIFOLD	1
30	1000327	BEARING	1
31	469587	ORIFACE	1
32	468694	SPINDLE NUT	1
33	491413	BOLT 1/4 NC X 3	2
34	467699	PIN SPINDLE LOCK	1

Item No.	RRP Part Number	Description	Qty
35	395246	SPRING SPINDLE LOCK	1
36	469985	HANDLE GRIPS	2
37		FITTING 45°	2
38	468770	RETAINER SEAL/ SPOOL	1
39	466535	LINK VALVE	1
40	466161	O-RING BACK-UP	2
41	466162	O-RING	2
42		PLATE MOTOR	1
43	468695	FLANGE DRIVE	1
44	468696	FLANGE OUTER	1
45	468697	SPACER MOTOR MOUNT	1
46	469715	SPINDLE	1
47	470834	ROLL PIN	2
48	468652	BOLT 3/8 X 3/4 BHAS	2
49	10000334	HYDRAULIC MOTOR	1
50	467989	SPINDLE	1
51	468771	SPRING	1
52	466864	WHIPER	1
53	468772	SPACER	1
54		FRAME	1
55	469986	AXLE ROLLER	1
56	469987	ROLLER TUBE	1
57	469988	BEARING	2
58	469646	FRAME HANDLE	1
59		HOSE HYDRAULIC	2
60	459909	FITTING 90°	2
61	10000337	GUARD STONE	1
62	1000349	MOUNT GUARD	1
63		LOCKING LEVER	1
64	400684	BOLT ¼ X ¾	3
65		SPACER	2