

Lag Driver
910156
Operating and Maintenance Manual



Lag Driver

910156

Record of Changes

Rev No.	Date	Description of Changes
Rev 1	11.2015	New product
Rev 2	1.2019	Content update with new branding
Rev 2.1	12.2020	Add Service Part

Contents

Section 1: Overview and Safety 4

Lag Driver Overview 4

Warranty Terms and Conditions 4

Safety Information 6

 Safety Terms 6

 Machine Use and Safety Precautions 6

Section 2: Specifications and Installation 7

Specifications 7

Adapter Kits 9

 Rectangle Driver Adapter 9

 Dome Head Adapter 9

 Torque Drive Adapter 9

 25 Pin Skid Plate 10

Installation Instructions 10

Hose Requirements 11

 Hose Types 11

 Hydraulic Hose Recommendation 12

 Hydraulic Fluid Recommendation 12

 Hose Connecting Procedures 13

 Disconnecting Hoses 14

Section 3: Tool Operation 14

Section 4: Maintenance 15

Trouble Shooting 17

Section 5: Parts and Service Support 19

 Technical Support & Service 19

Lag Driver Assembly Drawing 21

 Lag Driver Parts List 23

Section 1: Overview and Safety

Lag Driver Overview

RRP designs and manufactures equipment primarily for the repair and new construction of rail and railroad tie track maintenance.

Our product line focuses on rail fastening application/removal/adjustment equipment, other tie material (OTM) reclamation, wood and concrete railway tie repair, and tie plate handling/distribution.

The Lag Driver is designed to screw a variety of lag bolt styles into ties from a standing position. This tool will help eliminate the use of other methods that increase the likelihood of injury. When properly used this tool will help reduce back strain and reduce operator fatigue.

- The lag driver requires a flow of 10 GPM (40 LPM) at 2000 psi (138 bar) for best performance
- Use this tool on an open center hydraulic system only with a maximum pressure of 2150 psi (148.3 bar).
- The lag driver uses a 1" square drive and requires high impact sockets.

Racine Railroad Products recommends the Racine Railroad Product Diesel Power Unit that can meet the needs for most hydraulic tools used by the rail road industry.

This power unit is capable of powering two tools simultaneously at 5 GPM (20 LPM) or one tool at 10 GPM (40 LPM) all the flows are at 2000 psi (138 bar).

The maximum pressure of the hydraulic system is limited to 2150 psi (148.3 bar). The power source provided the required flow and pressure to operate HTMA type I A 15-23 LPM (4-6 GPM) and type RR 34-40 LPM (9-10.5) tools.

All of which, are *open-center* tools required an operating pressure of 2000 psi (138 bar).

Warranty Terms and Conditions

Warranty Period

Each new machine and new parts of our manufacture are warranted against defects in material and workmanship for one year from the date of shipment from our factory.

When contacting customer service for factory parts, service or warranty support please provide the:

- Racine Railroad Products Model
- Serial Number
- Any locally assigned identification

Vendor Parts Warranty Period

Other equipment and parts used, but not manufactured by Racine Railroad Products, Inc., are covered directly by the manufacturer's warranty for their products.

Warranty Parts and Service

We will repair or replace, without charge, F.O.B. factory, Racine, Wisconsin, USA, any part Racine Railroad Products manufactures which is proven to be defective during the warranty period.

Material claimed defective must be returned, if requested, to the factory within 30 days from the date of the claim for replacement. Ordinary wear and tear, abuse, misuse and neglect are not covered by this warranty. Depending upon the circumstances, we may provide technical assistance and/or technical service support, without charge, to assist in the correction of warranty related problems.

Non-Warranty Parts and Service

Material damaged through normal wear and tear, abuse, misuse and/or neglect are not covered by our warranty and should be ordered directly from our Customer Service.

Note: Parts for models that are no longer in production may not be available.

Non-Warranty Parts Orders

When placing a parts order please provide the following information:

- Company Name and Billing Address
- Purchase Order Number and Issuing Authority
- Shipping Address
- Special Handling Instructions
- Contact Phone Number
- Machine Model and Serial Number
- Part Numbers and Quantities Being Ordered

Note: *Please use Racine Railroad Products part numbers when ordering parts.* Racine Railroad Products part numbers are shown in the parts lists and drawings of this manual and have only six (6) numbers.

Any part number with other than six numbers (e.g. contains alpha-numeric characters) is a Vendor Part Number and **not** a Racine Railroad Products part number

Safety Information

For safe installation and operation of this equipment, carefully read and understand the contents of this manual. Improper operation, handling, or maintenance can result in equipment damage and personal injury.

Only trained and authorized personnel should be allowed to operate this machine. In addition, all personnel at the worksite (gang) should be aware of the safety concerns and their individual responsibilities prior to working this machine.

Please read and comply with all the safety precautions in this manual **before** operating this machine. Your safety is at risk.

Safety Terms



DANGER indicates a hazardous operating procedure, practice, or condition. If the hazardous situation is not avoided death or serious injury will occur.



WARNING indicates a hazardous operating procedure, practice, or condition. If the hazardous situation is not avoided death or serious injury could occur.



CAUTION indicates a potentially hazardous operating procedure, practice, or condition. If the hazardous situation is not moderate or minor injury could occur.

Note: Indicates an essential operating procedure, practice, or condition. No personal injury is possible.

Machine Use and Safety Precautions



Failure to follow safety precautions when operating this equipment can result in serious injury or death to the operator or other persons in the area. Observe the following precautions whenever you are operating, working on or near this equipment.

Do not use this machine for other than its intended purpose.

Do not make any modifications without authorization or written approval from Racine Railroad Products. Replace all Racine Railroad Products and OEM parts with genuine Racine Railroad Products and OEM parts. Using non-OEM parts may compromise the safety of the machine.

Do not wear loose clothing, jewelry, radio belts, etc., when operating, working on or near this equipment. They can be caught in moving parts and may result in severe injury.

Always wear appropriate personal protective clothing when operating this equipment: e.g. Orange safety vest, hard hat, safety glasses with side shields, hearing protection, steel-toed safety boots, leather gloves, dust respirator, etc.

Always lift heavy objects with the knees and legs, not the arms and back.

Always keep hands, arms, feet, head, clothing, etc., out of the operating area and away from all rotating or moving components when operating, working on or near this machine.

Always make sure that all guards, covers, belts, hoses and operating components are in good working order and that all controls are in the appropriate position before starting the engine.

Always make sure that all safety equipment installed properly and are in good working order. Do not operate the machine until unsafe conditions have been corrected.

Always operate in a well-ventilated area and make sure that the air filters, air filter covers, and muffler are in good condition.

Always keep the machine clean and free of debris. Operate the machine in a safe and responsible manner. Exercise caution when fueling, working on or near rotating or moving components, hot components and fuel systems. Be aware of potential fire hazards and prevent sparks, exhaust, etc., from starting fires on the machine and/or work area.

Always comply with all instructions provided on any decals or placards installed on the machine and with any relevant amplifying information provided in this manual or other general operating procedures.

Always shut disconnect the power source and make sure that all controls are in a safe position and install all appropriate locking and safety devices before doing any of the following:

- Lubricating
- Adjusting
- Installing Tooling
- Making Repairs
- Performing Service

Section 2: Specifications and Installation

Specifications

Physical

Circuit..... 10 GPM @ 2000 psi / 40 LPM @ 83-138 bar

Length..... 32 in. / 81.2 cm

Width..... 19 in. / 48.2 cm

Height 4.5 in. / 11.4 cm

Weight (Dry..... 33 lbs / 14.9 kg

Hydraulic Fluid Requirements [Viscosity (Fluid Thickness)]

USA	Metric
50° F 450 SSU Max	10° C 95 Centistokes
100° F 130-200 SSU	38° C 27-42 C.S.
140° F 85 SSU Min.	60° C 16.5 C.S., Min.

- Pour Point 10° F / 23° C Minimum (for cold startup)
- Viscosity Index (ASTM D 2220)..... 140° F Minimum
- Demulsibility (ASTM D-1401) 30 Minutes Maximum
- Flash Point (ASTM D-92) 340° F / 171° C Minimum
- Rust Inhibition (ASTM D-665 A & B) ... Pass
- Oxidation (ASTM D943) 1000 Hours Minimum
- Pump Wear Test (ASTM D2882)..... 60 mg Maximum

Lag Driver Components

The Lag Driver is operated from a T style handle.

- On the T style handle is a trigger that is used to operate the driver (Arrow A).
- A trigger lock prevents accidental operation of the tool (Arrow B).
- Hose whips move the hydraulic couplers away for operator’s hands making the tool easy to handle (Arrow C).
- The manifold features a push button to reverse the direction of rotation (Arrow D).

The driver is a 1” square drive and has a quick attach mounting bracket, for mounting the drive options.

- A grease zerk allows lubrication of the internal impact components without disassembling the tool (Arrow E).

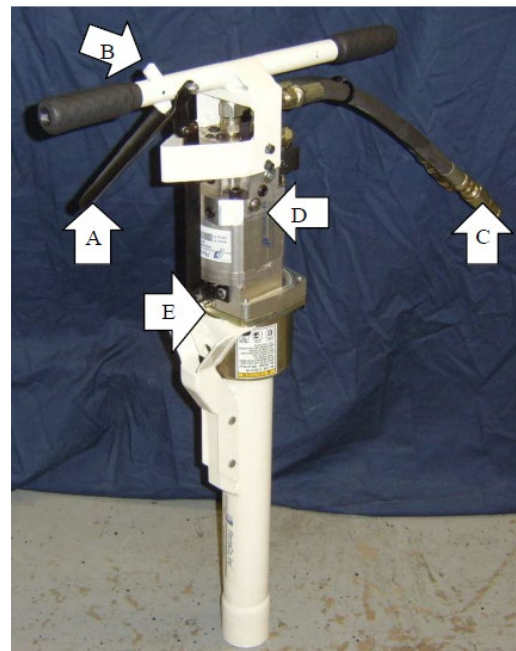

Coupler Recommendation

3/8 inch Flat Face HTMA couplers rated at 2500 psi working pressure. Threads are to match fittings used on hoses or fittings used as adapters.

Bolt Size	Torque
#10-32	38 in-lb
1/4-20	76 in-lb
5/16-18	13 ft-lb
3/8-16	23 ft-lb

Adapter Kits

Rectangle Driver Adapter

The Rectangle Drive Adapter is used for installing and removing lag screws with a rectangle head with a spring washer, under its head.

The extension housing has magnets installed in the tube wall, and the socket has a magnet installed in it also, to hold the lag screw in position when installing it.



Rectangle Head Style Lag Screw

Dome Head Adapter

The Dome Head Adapter is used for installing and removing dome head style lag screws.

The extension housing covers all moving parts except the portion of the socket which is required to engage the lag head.



Dome Head Style Lag Screw

Torque Drive Adapter

Torque Drive Adapter is used for installing and removing torque head lag screws.

The extension housing covers all moving parts except the portion of the socket which is required to engage the lag head.



Torque Head Style Lag Screw

25 Pin Skid Plate

The 25 Pin Skid Plate features receivers for 25 lag screws of any style.

A chain handle is used to pull the skid plate, with the lag screws, along with the operator.



25 Pin Skid Plate features

All adapter kits contain all the components required to mount to the, lag driver. Some of the components may duplicate parts already in other kits, keep these on hand and use as replacement parts when required.

The kits slide over the end of the impact head and mount with two ¼ inch bolts, supplied with each kit. See individual kits for proper mounting procedures.

Installation Instructions

Unpacking Instructions

Upon receiving your Lag Driver promptly remove it from the shipping container. Always keep top side of container up. Inspect unit for damage which may have incurred during shipping and report it to carrier for claim.

Tool Preparations

The Lag Driver is ready for use after unpacking and no special preparation is required. If the tool is used in cold weather, preheat the hydraulic fluid by running power source at low engine speed.

Fluid temperature should be at or above 50° F/10° C (400-ssu / 82 centistoke) before use, when using recommended fluids. Using too thick of fluid may result in tool damage.



Never stick foreign objects, fingers, or other extremities into moving mechanism. Failure to follow these instructions may lead to severe personal injury or tool damage.

Before operating the Lag Driver, it is important to inspect the trigger linkage mechanism for obstructions. Make sure all sockets are securely mounted. Follow all safety precautions when inspecting tool.

- Connect the tool to the power source.
- Hold the impact by the handles resting it on the ground.
- When the trigger is pulled, the socket should rotate.
- Release the trigger and allow the socket to stop rotating.
- Press the button to reverse the rotation and check that the tool rotates in both directions.



When operating the Lag Driver do not change the rotation without letting the socket stop rotating completely. Be sure to follow all safety guidelines.

Hose Requirements

It is not often necessary or advisable to use long hoses. All hoses must have an oil resistant inner surface and an abrasion resistant outer surface. Each hose must have male pipe ends for most application.

Longer hoses can be used when necessary but can affect the operation of the tool due to resistance in the hose.

If small diameter or long hoses are used, or if restrictive fittings are connected to the supply and return ports, the pressure required to push the fluid through the system and back to the tank will be higher. This will reduce tool power.

Important: Oil should always flow from the male coupler through the female coupler.

Note: The pressure increases in uncoupled hoses left in the sun. This may make them difficult to connect. When possible after use, connect the free ends of the operating hoses together.

Hose Types

Hydraulic hose types authorized for use with the Lag Driver are:

1. Labeled and certified nonconductive.
 - This is the only hose authorized for use near electrical conductors.
2. Wire braided (conductive)
 - This hose is conductive and must never be used near electrical conductors.
3. Fabric braided (not certified or labeled non-conductive)
 - This hose is conductive and must never be used near electrical conductors.

The rated working pressure of the hydraulic hose must be at least 175 bar (2500 psi).

Hydraulic Hose Recommendation

Hydraulic Hose Recommendation								
Flow Per Circuit		Length Each Hose		Use	Inside Diameter		SAE Spec Hose (Wire Braid)	SAE Spec Hose (Fiber Braid)
GPM	LPM	Feet	Meter		Inch	MM		
5 to 8	19 to 30	To 50	To 15	Both	1/2	13	SAE 100R1-8	100R7-8
5 to 8	19 to 30	51 to 100	15 to 30	Both	5/8	16	SAE 100R2-10	SAE 100R8-10
5 to 8	19 to 30	100 to 300	30 to 90	Pressure Return	5/8	16	SAE 100R2-10	SAE 100R8-10
					3/4	19	SAE 100R1-12	SAE 100R7-12
9 to 12	34 to 45	To 50	To 15	Both	5/8	16	SAE 100R2-10	SAE 100R8-10
9 v 12	34 to 45	51 to 100	15 to 30	Pressure Return	5/8	16	SAE 100R2-10	SAE 100R8-10
					3/4	19	SAE 100R3-12	SAE 100R7-12
9 to 12	24 to 45	100 to 200	30 to 60	Pressure Return	3/4	19	SAE 100R2-12	SAE 100R8-12
					1	25.4	SAE 100R1-16	SAE100R7-16

The rated working pressure of the hydraulic hose must be at least 2500 psi / 173 bar.

Hydraulic Fluid Recommendation

Inspect hoses for cuts, crushing, leaks, or abrasion, which may be a safety hazard or reduce fluid flows.

The following fluids work well over a wide temperature range at startup, allow moisture to settle out, and resist biological growth likely in cool operating hydraulic circuits.

Others that meet or exceeds the specifications of these fluids may also be used.

Type	Hydraulic fluid
Chevron	Clarity AW 15032
Exxon	Univis J 32
Mobil	D.T.E. 13M
Gulf	Harmony AW-HVI-150-32
Shell	Tellus T 32
Texaco	Rando HDZ 32
Union	Unax AW-WR-32
Amsoil	AWH 15032
Sunvis	Low Pour H/032-product code 19300

Hose Connecting Procedures

1. Stop the engine before connecting the tool and or hoses to the OFF power unit, and when switching hoses or tools.
2. Turn the hydraulic on/off valve to the off position before starting the engine.

Make sure all hoses are connected for correct flow direction to and from the tool being used.

When routing hose in the work area, position them where personnel will not be at risk of tripping over them where vehicles can run over the hoses. Do not lay hose over sharp objects.



Pressurized fluid escaping from a damaged hose can penetrate the skin and be injected in the body causing injury or death.

Do not pull on hoses to drag the power unit or tool.

Connecting Hoses

1. Wipe quick couplers with a clean lint free cloth before connecting them.
2. Depressurize the system.
3. Allow system and hydraulic fluid to cool if too hot to handle.
4. Securely connect the return (tank “R”) hose from the power source to the tool.
5. Securely connect the supply (pressure “P”) hose from the power source to the tool.

It is recommended that you connect the return hoses first and disconnect last to minimize or avoid trapping pressure within the tool.

When connecting the quick couplers, the flow should run from male coupler to the female coupler. The female coupler on the tool is the inlet. Quick couplers are marked with a flow direction arrow.



Pressurized fluid escaping from a damaged hose can penetrate the skin and be injected in the body causing injury or death.

Do not pull on hoses to drag the power unit or tool.

Note: When possible, connect the free ends of uncoupled hoses to prevent build up in the hoses. The sun can also increase pressure in the hoses and make connecting them difficult.

1. Grip the handles firmly with both hands.
2. Pull down with thumb on the safety lock and pull the trigger to the handle to start the grinder.
3. When starting the tool, hold it off from all surfaces.
4. Start grinding with the tool running.
5. When finished, release trigger and allow stone to stop turning and make sure trigger is in the locked position before placing the tool on any surface.

Disconnecting Hoses

1. Stop the hydraulic power source.
2. Depressurize the system.
3. Allow system and hydraulic fluid to cool.
4. Disconnect the supply (pressure) hose to the power source (pressure port) from the tool (IN port).
5. Disconnect the return (tank) hose to the hydraulic power source (return port) from the tool (OUT port).
6. To prevent contamination, always install dust caps over the hydraulic ports of the tool when disconnected.



If injury results from escaping hydraulic fluid, seek immediate medical attention. Serious bodily injury may occur if proper medical attention is not administered immediately.

Do not attempt to locate hydraulic leaks by feeling around hoses and fittings with your hands. Pinhole leaks can penetrate the skin.

Section 3: Tool Operation

1. Position the socket end over the lag to be installed or removed.
 - Use only sockets designed to drive the style of lag screw being used.
2. Shift the spool to the direction of rotation desired.
 - Hold the tool with the trigger in the right hand and push the spool towards the operator to rotate the socket in the clockwise direction.
 - Push the spool away from the operator to rotate the socket in the counter-clockwise direction.



Do not shift the spool while the tool is operating, damage to internal components may occur.

3. Hold the tool securely with both hands. Press the trigger-lock down and pull the trigger.
 - To stop the driver, release the trigger.

Note:

- When the lag contacts the surface of the material being fastened, limit impact time to 10 seconds.
- Excessive wear will occur to the hammer mechanism due to the heat buildup.
- When removing a lag, run the impact driver until the lag is clear of the hole.
- Remove the driver from the lag a move on to the next lag.

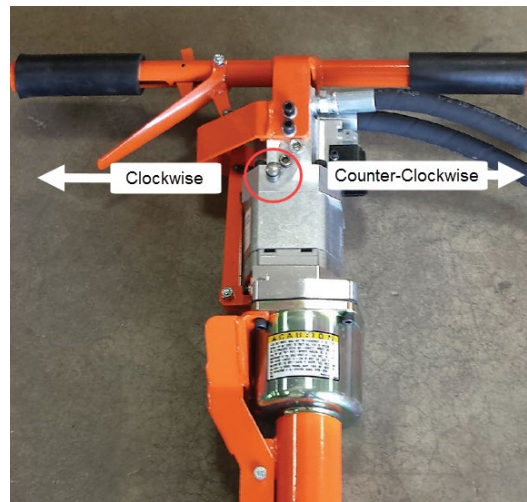

Section 4: Maintenance

It is highly recommended to practice regular check-ups and maintenance in accordance with the usage frequency to keep your tool in better condition and reduces total running costs.



WARNING Do not perform maintenance on the Lad Driver while the hydraulic power source motor is running or when hoses are connected.

All maintenance must be done with the tool disconnected from power source.

Cleaning and Maintenance Recommendations

- Wipe all external surfaces after each use with a clean, lint free cloth to remove surface contaminants from the tool.
- To extend the life of the handle padding, do not allow sharp edges or foreign objects to rub on the padding.
- Store all tools in an enclosed area to prevent weather from contaminating their systems.

Safety Devices

When maintenance is complete, make sure the following:

- The hydraulic control valves are operable.
- The hydraulic quick couplers and hoses are safe to use.
- Weekly lubrication of the gripper cams and gripper arms.
- The gripper pads are in good condition.

Daily



WARNING Do not attempt to locate hydraulic leaks by feeling around hoses and fitting with hand. Pin-Hole leaks can penetrate the skin.

- Wipe all tool surfaces, fittings, and couplings free of grease, dirt, and foreign materials.
- Inspect the tool, hydraulic system, hoses, and fittings for signs of leaks, cracks, wear, and/or damage. Replace if necessary.
- To prevent contamination, always install dust caps over the hydraulic ports when disconnected.

Weekly Maintenance

Grease the impact mechanism using the grease zerk located on top of the motor adapter plate.

Apply 2 to 3 strokes (approximately 4 cc's) from a standard grease gun using Mobil HP 53019-6 or equivalent grease.

- Grease leakage from around the square drive is common after lubrication and during hard use. Wipe the grease off to prevent it from splattering all over.

Note: Do not attempt to repair this product. Only properly trained personnel should perform any maintenance service, and or repair to this tool.



Monthly Maintenance

- Perform a detailed inspection of the systems hoses, and fittings according to the hydraulic hose operator's manual and as stated in SAE standard j1273, May 1989 or latest revision.
- Replace the hoses and/or fittings if necessary.

Semi-Annually

- Remove the impact head (Item 37) and clean the grease off the impact components.
- Remove the grease from the impact housing.
- Remove the thrust washers (Item 39) and thrust bearing (Item 38) and wipe clean.
- Before reinstalling them, check for damage and replace if in poor condition.
- Mount the impact head (Item 37) to the motor adapter plate (Item 29) after placing the assembled hammer mechanism in the impact head.
- Make sure all the shims (Item 43) are in position before mounting the impact head.
- There may be more than one shim. After assembly, apply 100 strokes of grease (133 cc's) to the lubricating zerk.

Cold Weather Operation

Hydraulic fluids are thicker in cold weather; therefore, run the engine at low idle long enough to bring the fluid temperature up to minimum of 10°C/50°F or until the top of the hydraulic tank feels warm, before operating tool.

Storage Preparation

The tool should be stored in a cool, dry environment which is not subjected to rapid temperature changes.

- Cover male and female hose whips.
- Store in the upright position.
- Secure tool to prevent it from being knocked over.
- Store the Lag Driver on a smooth level surface.

Troubleshooting

The following chart can be used as a guide to correct any problem you may experience with the tool.

To determine the problem in operation of the lag driver always check that the hydraulic power source is supplying the correct hydraulic flow and pressure to the tool as listed in the table. Be sure you are using an accurate flow meter. Check the flow with the hydraulic fluid temperature at least 80° F / 27° C.

Note: Stop and depressurize the hydraulic system before connecting or disconnecting a tool.

Failure to follow these instructions can lead to severe personal injury. Read and follow the instructions in this manual for the proper way to connect and disconnect tools from the hydraulic systems.

Problem	Cause	Remedy
Tool will not run or runs slow.	Power source.	Check power source flows and pressure (5-10 GPM/20-38 LPM at 1500-2000 psi/100-140 bar).
	Coupler or hose.	Check for /remove obstruction.
	Directional spool not fully shifted.	Shift spool to either position.
	If after impact mechanism has been serviced.	Check that all shims have been placed back between the impact head and adapter. Run impact to circulate grease.
	Mechanical failure.	Disassemble tool and check for damage.

Troubleshooting Continued

Poor impact performance.	Pressure and return hoses reversed.	Correct for proper flow direction.
	Worn impact components.	Disassemble front half of impact and check for damaged or severely worn parts.
	Incorrect grease.	Remove and clean impact head (see maintenance section for procedures).
	Cold hydraulic fluid.	Allow power source to warm up.
Trigger hard to pull.	Back pressure too high.	Should not exceed 250 psi/ 17 bar and 10 GPM /38 LPM.
	Dirty spool.	Remove and clean spool and replace O-rings and backups.
	Control linkage.	Inspect linkage between trigger and valve spool.
Hydraulic fluid leaks between motor and manifold block.	Damaged seal.	Disassemble tool and replace seal.
Hydraulic fluid leaks between adapter and motor.	Damaged shaft seal.	Split tool between adapter and motor and replace seal.
Hydraulic fluid leaks from control spools.	Damaged seals.	Replace all O-rings and backups on leaking spool.
Grease leaks between impact head and adapter.	Loose fasteners.	Tighten bolts.
Grease leaks around impact drive shaft.	Heavy duty use.	Normal due to heat buildup.
	Impact mechanism over greased.	Wipe clean until grease stops leaking, adjust greasing maintenance to match duty cycle.
Grease leaks around impact drive shaft when cold.	Anvil bushing worn.	Replace anvil bushing.

Section 5: Parts and Service Support

Technical Support & Service

Telephone and web-based technical support is available for current production models through our Technical Service Department. Service Manuals and limited technical support may be available for models that are no longer in production.

Telephone and E-mail Technical Support

Telephone and E-mail technical support is available on normal U.S. business days from 8:00 AM to 5:00 PM U.S. Central Time Zone (GMT +6 (+5 Daylight Savings Time)). Contact us at:

Phone: (262) 637-9681

E-mail: techserv@racinerailroad.com

Non-Warranty Technical or Field Service Support

Depending upon the circumstances and availability of technical service personnel, we may provide technical assistance and/or field service support, *at the customer's expense*, to assist in the correction of non-warranty related problems. Contact our Technical Service Department to coordinate Non-Warranty Technical or Field Service Support.

Warranty Technical or Field Service Support

Depending upon the circumstances and availability of technical service personnel, we may provide technical assistance and/or field service support, *at no charge to the customer*, to assist in the correction of warranty related problems. Contact our Technical Service Department to coordinate Warranty Technical or Field Service Support.

Warranty Parts and Service

Warranty parts and service are coordinated through our Technical Service Department.

Warranty Parts Claims

Material claimed to be defective must be returned to our factory for evaluation. Defective materials will be replaced, or your account will be credited if replacement materials have already been purchased. Please contact our Technical Service Department at the address provided below if you have any questions or problems.

Warranty Service Support

Depending upon the circumstances and availability of technical service personnel, we may provide technical assistance and/or field service support, *at no charge to the customer*, to assist in the correction of warranty related problems. Contact our Technical Service Department at the address provided below to coordinate Warranty Technical or Field Service Support.

Technical Specifications

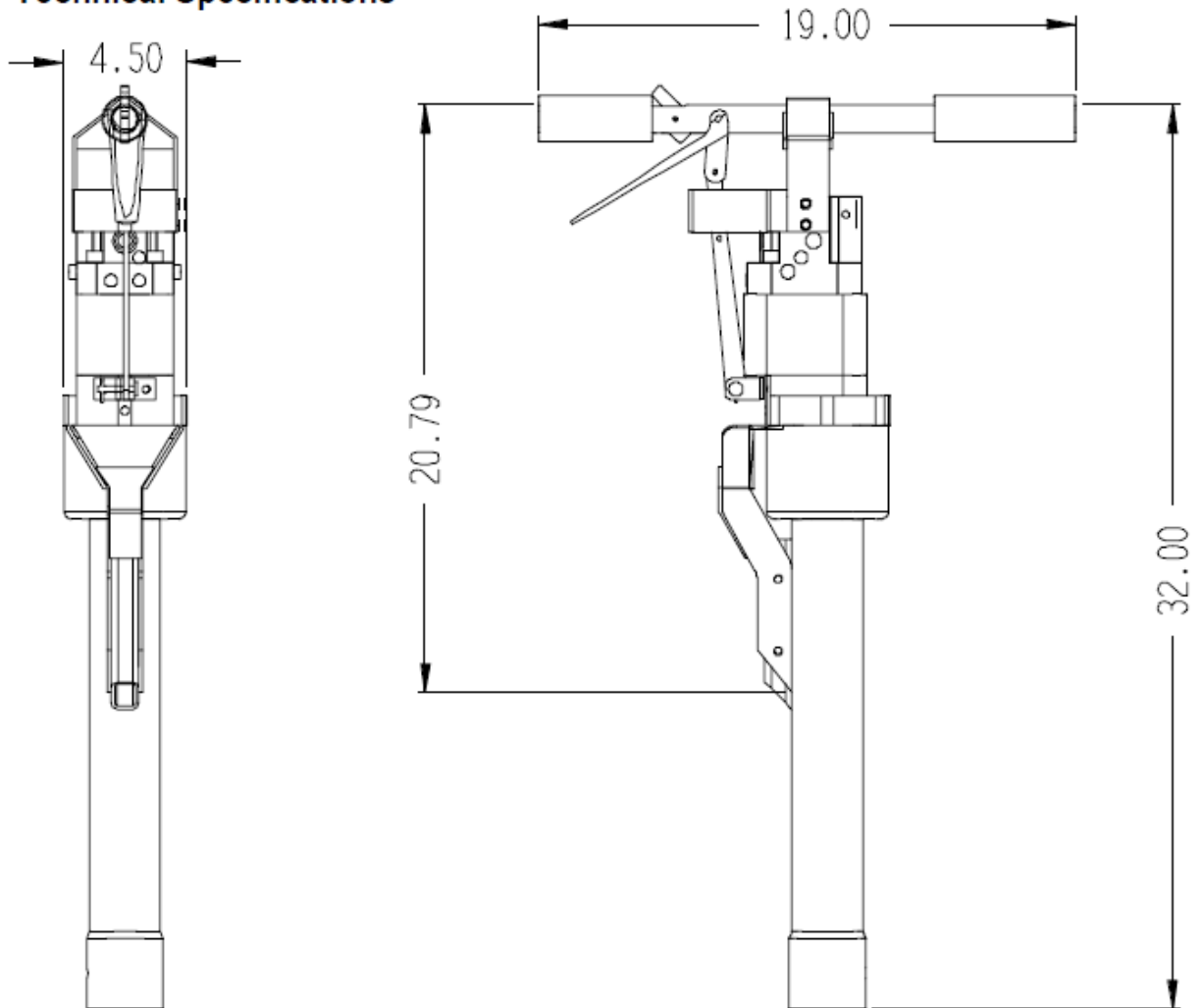

SHOWN WITH RECTANGLE DRIVE ADAPTER

Lag Driver Assembly Drawing

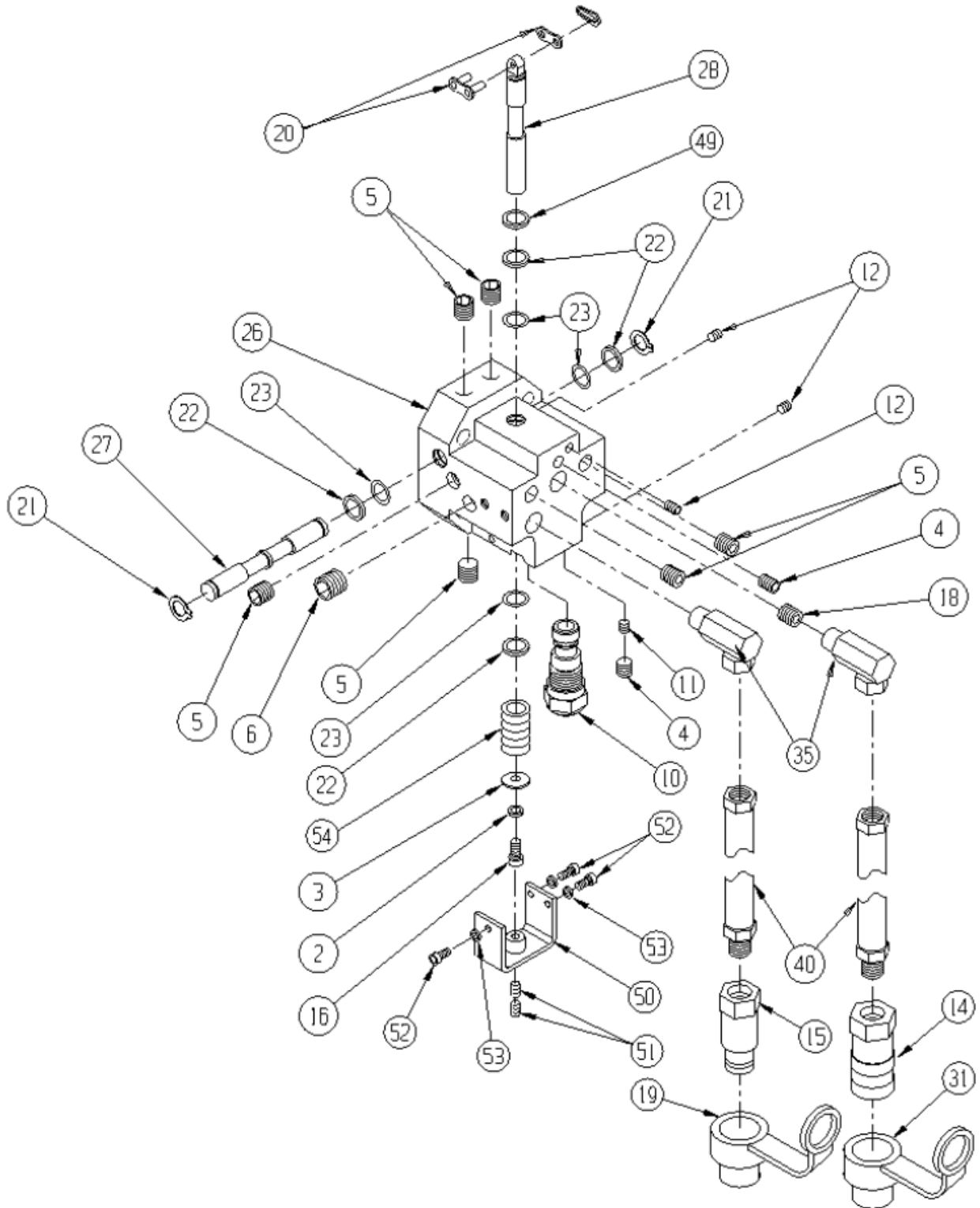

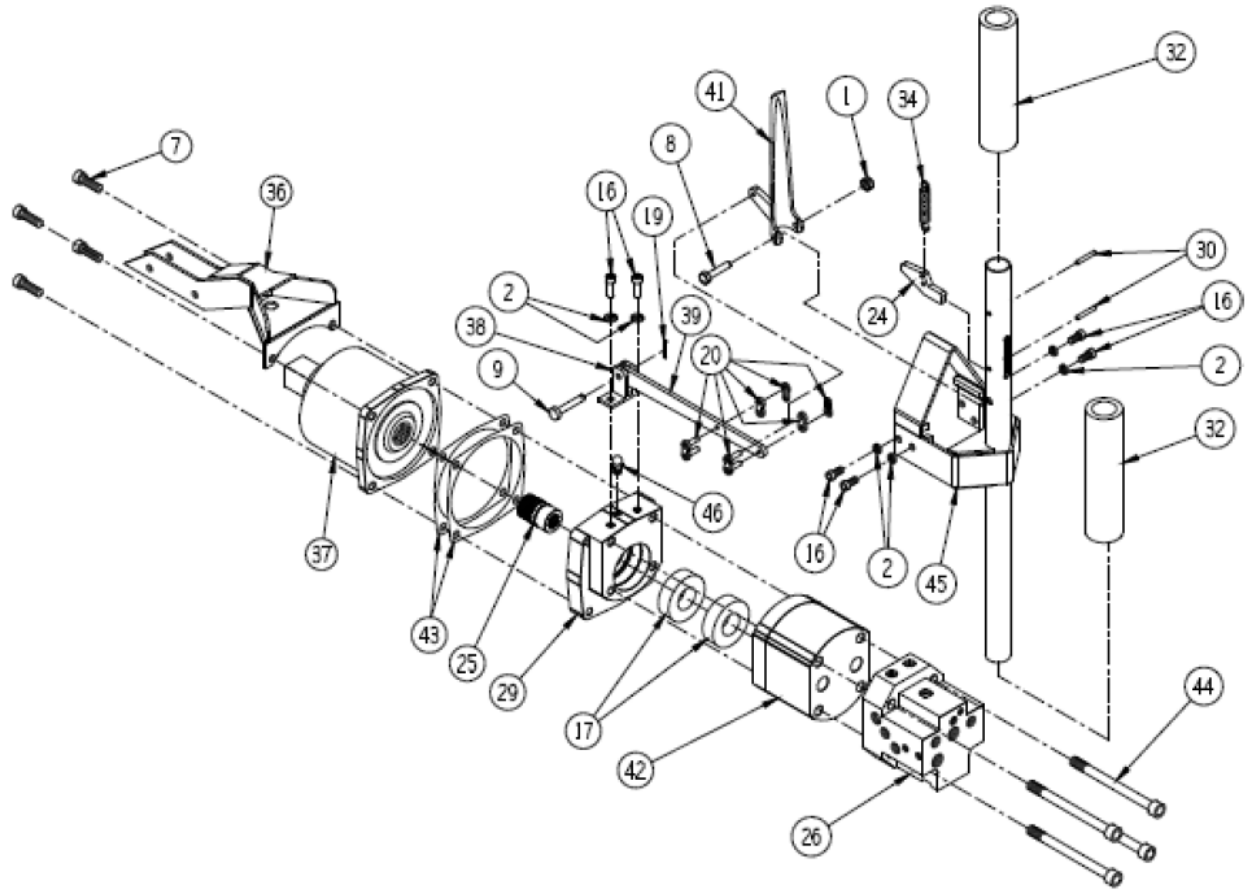

Lag Driver Parts List

Item	Description	Qty
1	NUT 1/4nc NYLOCK	2
2	LOCK WASHER ¼	3
3	WASHER ¼ FLAT	1
4	FITTING 1/8 PLUG ALLEN	2
5	PLUG ¼ ALLEN	6
6	PLUT 3/8 ALLEN	1
7	BOLT 5/16nc X 1 SHCS	8
8	BOLT 1/4nc X 1-3/4	1
9	BOLT ¼ X 1.00	1
10	VALVE FLOW	1
11	ORIFICE .024	1
12	PLUG 1/16 NPT ALLEN	3
13	WASHER 5/15 LOCK	4
14	COUPLER HYD FEMALE	1
15	COUPLER HYD MALE	1
16	BOLT ¼ nc X ½ SHCS	3
17	BEARING	2
18	ORIFICE .21	8
19	COVER DUST	1
20	LINK VALVE #41	2
21	SNAP RING ½	2
22	BACK-UP -014	4
23	QUAD RING -014	4
24	TRIGGER SAFETY STOP	1
25	COUPLER SLINE	1
26	MANIFOLD CONTROL	1
27	SPOOL DIRECTIONAL	1

Item	Description	Qty
28	SPOOL ON/OFF	1
29	PLATE MOTOR ADAPTER	1
30	PIN ROLL .156 X 1.00	2
31	COVER DUST	1
32	HAND GRIP	2
33	GRAPHIC SET COMPLETE	1
34	SPRING TRIGGER STOP	1
35	FITTING SHORT 90°	2
36	MOUNT EXTENSION GUARD	1
37	HEAD IMPACT	1
38	BRACKET MOUNT	1
39	LINK ON/OFF	1
40	HOSE WHIP	2
41	TRIGGER	1
42	MOTOR HYDRAULIC	1
43	SHIM STOCK	1
44	BOLT 3/8 X 4-1/2 SHCS	4
45	HANDLE COMPLETE	1
46	ZERK GREASE 1/8	1
49	WIPER SEAL	1
50	SPOOL STOP	1
51	SCREW SET SOCKET ¼-20 X 3/8	2
52	BOLT #10-24 X ½ SHCS	3
53	WASHER LOCK #10	3
54	SPRING	1

For Service Only

- BAR, HANDLE RRP# 475629